



INSTYTUT TECHNIKI BUDOWLANEJ

PL 00-611 WARSZAWA

ul. Filtrowa 1

tel.: (+48 22) 825-04-71

(+48 22) 825-76-55

fax: (+48 22) 825-52-86

www.itb.pl



Member of



www.eota.eu

European Technical Assessment

**ETA-17/0676
of 29/09/2017**

General Part

Technical Assessment Body issuing the European Technical Assessment

Instytut Techniki Budowlanej

Trade name of the construction product

PS Collar
PS-25 Wrap

Product family to which the construction product belongs

Fire Stopping and Fire Sealing Products.
Penetration Seals

Manufacturer

DUNAMENTI TUZVEDELEM ZRT
Nemeskeri Kiss Miklos u. 39
2131 God
Hungary

Manufacturing plant

DUNAMENTI TUZVEDELEM ZRT
Nemeskeri Kiss Miklos u. 39
2131 God
Hungary

This European Technical Assessment contains

48 pages including 3 Annexes which form an integral part of this Assessment

This European Technical Assessment is issued in accordance with regulation (EU) No 305/2011, on the basis of

Guideline for European Technical Approval "Fire Stopping and Fire Sealing Products – Part 2: Penetration Seals" ETAG 026-2, edition August 2011, used as European Assessment Document (EAD)

This European Technical Assessment is issued by the Technical Assessment Body in its official language. Translations of this European Technical Assessment in other languages shall fully correspond to the original issued document and shall be identified as such.

Communication of this European Technical Assessment, including transmission by electronic means, shall be in full. However, partial reproduction may only be made with the written consent of the issuing Technical Assessment Body. Any partial reproduction has to be identified as such.

VZOR

VZOR

Specific Part

1 Technical description of the product

PS Collar is a collar pipe closure device used to form penetration seals where combustible pipes penetrate walls and floors.

PS Collar includes one or more layers of an intumescent, graphite based liner with a nominal thickness of 2,5 mm and width 30 or 60 mm, inserted into a steel case.

The housing of the collar can be made of galvanized steel sheet with a thickness of 0,7 mm or stainless steel sheet with a thickness of 0,5 mm. The housing is equipped with a buckle (used to fasten the collar and stabilize it on the service) and with fixing brackets, through which the collar is fixed to the separating element. The number of brackets depends on the size of the collar.

The collar is supplied in assembled form, without fasteners. If necessary, the intumescent liner may be cut to a required length, equal or greater than external circumference of the pipe. The collar is wrapped around the service, closed and then fixed to the separating element with the specified type and number of fasteners.

Types of PS Collar, type of fasteners and required number of fixing brackets are presented in Annex A.

PS-25 Wrap is an intumescent wrap pipe closure device used to form penetration seals where combustible pipes penetrate walls and floors.

The PS-25 Wrap is supplied in roll form in 60 mm width and 2,5 mm thick. The length of rolls is 30 m. The wrap shall be wrapped around the pipe and may be cut to a required length, if necessary and then pushed into the aperture in the separating element.

The description of the installation procedure of PS Collar and PS-25 Wrap is given in Annex A.

2 Specification of the intended use in accordance with the applicable European Assessment Document (EAD)

2.1 Intended use

The intended use of PS Collar is to reinstate the fire resistance performance of flexible wall, rigid wall or rigid floor constructions where they are penetrated by combustible pipes.

The specific elements of construction that the PS Collar may be used to provide a penetration seal in, are as follows:

Rigid walls: The wall must have a minimum thickness of 100 mm and comprise concrete, reinforced concrete, aerated concrete, ceramic brick, cavity brick or checker brick, with a minimum density of 600 kg/m³.

Flexible walls: The wall must have a minimum thickness of 100 mm and comprise timber or steel studs lined on both faces with at least two layers (with overall board layer thickness equal to or greater than 25 mm) of 'Type F' or 'Type DF' gypsum plasterboards according to EN 520. In timber stud walls, no part of the penetration shall be closer than 100 mm to a stud, the cavity must be closed between the penetration seal and the stud and minimum 100 mm of insulation of reaction to fire class A1 or A2, according to EN 13501-1, is provided within the cavity between the penetration seal and the stud.

Rigid floors: The floor must have a minimum thickness of 150 mm and comprise aerated concrete, concrete or reinforced concrete with a minimum density of 600 kg/m³.

The intended use of PS-25 Wrap is to reinstate the fire resistance performance of rigid wall or rigid floor constructions where they are penetrated by combustible pipes.

The specific elements of construction that the PS-25 Wrap may be used to provide a penetration seal in, are as follows:

Rigid walls: The wall must have a minimum thickness of 100 mm and comprise concrete, reinforced concrete, aerated concrete, ceramic brick, cavity brick or checker brick, with a minimum density of 600 kg/m³.

Rigid floors: The floor must have a minimum thickness of 150 mm and comprise aerated concrete, concrete or reinforced concrete with a minimum density of 600 kg/m³.

The supporting construction shall be classified in accordance with EN 13501-2 for the required fire resistance period (equal or greater than specified in Annex C).

PS Collar and PS-25 Wrap may be used to provide a penetration seal with specific combustible pipes (according to Annex C).

Pipes shall be supported at maximum 200 mm away from both faces of the wall constructions and from the upper face of floor constructions.

The performances given in this European Technical Assessment are based on an assumed working life of the PS Collar and PS-25 Wrap of 10 years. The indications given on the working life cannot be interpreted as a guarantee given by the producer or the Technical Assessment Body, but are to be regarded only as a means for choosing the right products in relation to the expected economically reasonable working life of the works.

2.2 Use category

Type Z₁: intended for use in internal conditions with humidity equal to or higher than 85% RH, excluding temperatures below 0°C, without exposure to rain or UV.

3 Performance of the product and references to the methods used for its assessment

3.1 Performance of the product

3.1.1 Safety in case of fire (BWR 2)

Essential characteristic	Performance
Reaction to fire	Class E
Resistance to fire	Annex C

3.1.2 Hygiene, health and the environment (BWR 3)

The applicant has submitted a written declaration that the products and/or constituents of the products contains no substances which have been classified as dangerous according to EOTA TR 034.

Regarding the dangerous substances, there may be requirements applicable to the products falling within its scope (e.g. transposed European legislation and national laws, regulations and administrative provisions). In order to meet the provisions of the Construction Products Regulation, these requirements need also to be complied with, when and where they apply.

3.1.3 Safety and accessibility in use (BWR 4)

No performance assessed.

3.1.4 Protection against noise (BWR 5)

No performance assessed.

3.1.5 Energy economy and heat retention (BWR 6)

No performance assessed.

3.1.6 General aspects relating to fitness for use

Essential characteristic	Performance
Durability and serviceability	Use category: Type Z ₁

3.1.7 Sustainable use of natural resources (BWR 7)

No performance assessed.

3.2 Methods used for the assessment

The assessment of fitness of the collar and wrap for the declared intended use in relation to the requirements for safety in case of fire and general aspects relating to fitness for use has been made in accordance with the ETAG 026-2 "Fire Stopping and Fire Sealing Products – Part 2: Penetration Seals", edition August 2011.

4 Assessment and verification of constancy of performance (AVCP) system applied, with reference to its legal base

According to Decision 99/454/EC of the European Commission, as amended by Decision 2001/596/EC of the European Commission the system 1 of assessment and verification of constancy of performance applies (see Annex V to Regulation (EU) No 305/2011).

5 Technical details necessary for the implementation of the AVCP system, as provided in the applicable European Assessment Document (EAD)

Technical details necessary for the implementation of the AVCP system are laid down in the control plan deposited in Instytut Techniki Budowlanej.

For type testing the results of the tests performed as part of the assessment for the European Technical Assessment shall be used unless there are changes in the production line or plant. In such cases the necessary type testing has to be agreed between Instytut Techniki Budowlanej and the notified body.

Issued in Warsaw on 29/09/2017 by Instytut Techniki Budowlanej

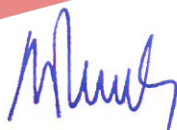

Anna Panek, MSc
Deputy Director of ITB

VZOR

Additional provisions

- The PS Collar shall be either fixed on both sides of the wall or fixed at the bottom of the floor (for details see Annex C).
- The PS-25 Wrap shall be placed in the separating element: in the centre of the wall thickness or on the bottom of the floor (single wrap) or symmetrically on both sides of the axis of the wall (two wraps) (for details see Annex C).
- The minimum distance between the penetration seals in supporting construction shall be 100 mm.
- The PS Collar shall be fixed to the wall or the floor by steel fasteners (M6x90 mm in case of walls and M6x60 mm in case of floors). Minimal number of fixing brackets and type of fastener is given in Table A.1. Types of PS Collar (different housings) are presented in Annex B.

Table A.1

Separating Element / Type of fastener	PS Collar type acc. to Annex B ¹⁾	Minimal number of fixing brackets
Wall / M6x90	DN50 / DN63	3
	DN75 / DN125	4
	DN90 / DN200	5
	DN110 / DN225 / DN250	6
	DN160	8
Floor / M6x60	DN50 / DN63	3
	DN75 / DN125	4
	DN90 / DN200	5
	DN110 / DN225 / DN250	6
	DN160	8

¹⁾ the number in collar type indicates maximum outer diameter of pipe or pipe bundle in millimeters

- Classifications given in Annex C are valid for specific pipes made of:
 - PVC-U according to EN 1329-1, EN 1453-1 or EN 1452-1,
 - PVC-C according to EN 1566-1,
 - PE-HD according to EN 1519-1 or EN 12666-1,
 - PE according to EN 12201-2, EN 1519-1 and EN 12666-1,
 - ABS according to EN 1455-1,
 - SAN + PVC according to EN 1565-1 or
 - PP-R according to EN ISO 15874, according to tables in Annex C.
- The width of the gap around the pipe or pipe bundle should be less than or equal to 15 mm and should be filled with cement or gypsum mortar.
- Pipes are placed in angle 90° to the supporting construction, unless specified otherwise.

PS Collar and PS-25 Wrap	Annex A
Additional provisions	of European Technical Assessment ETA-17/0676

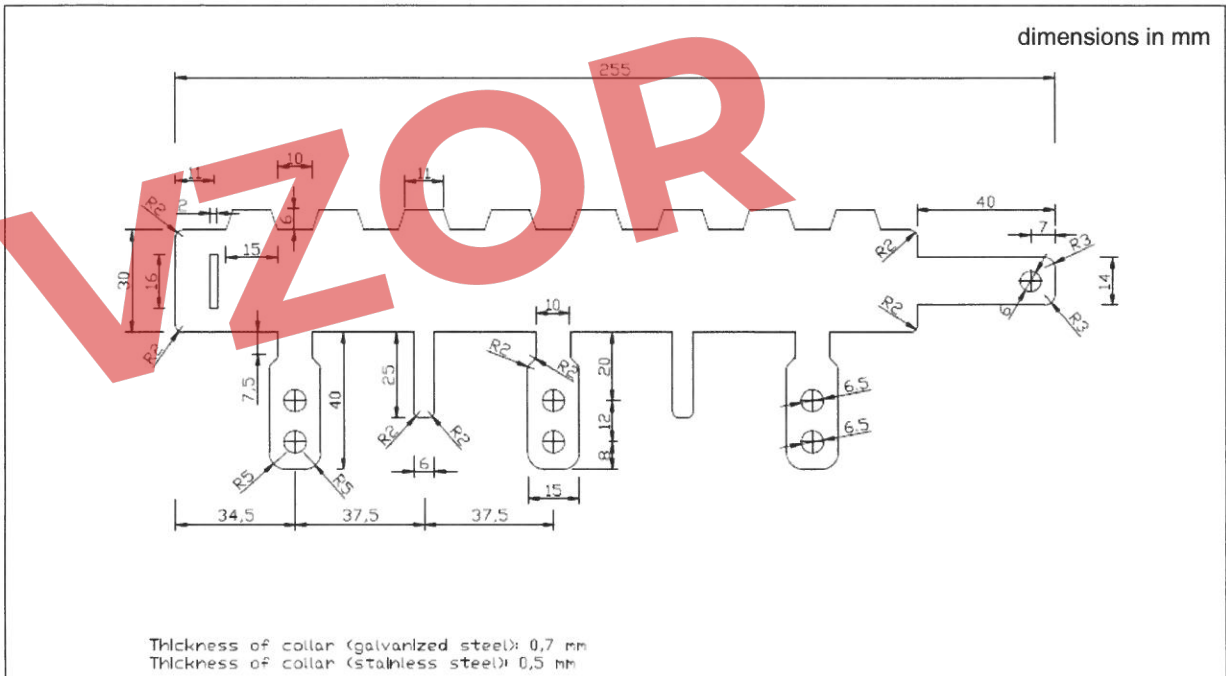

Fig. B1. Housing of PS Collar DN50

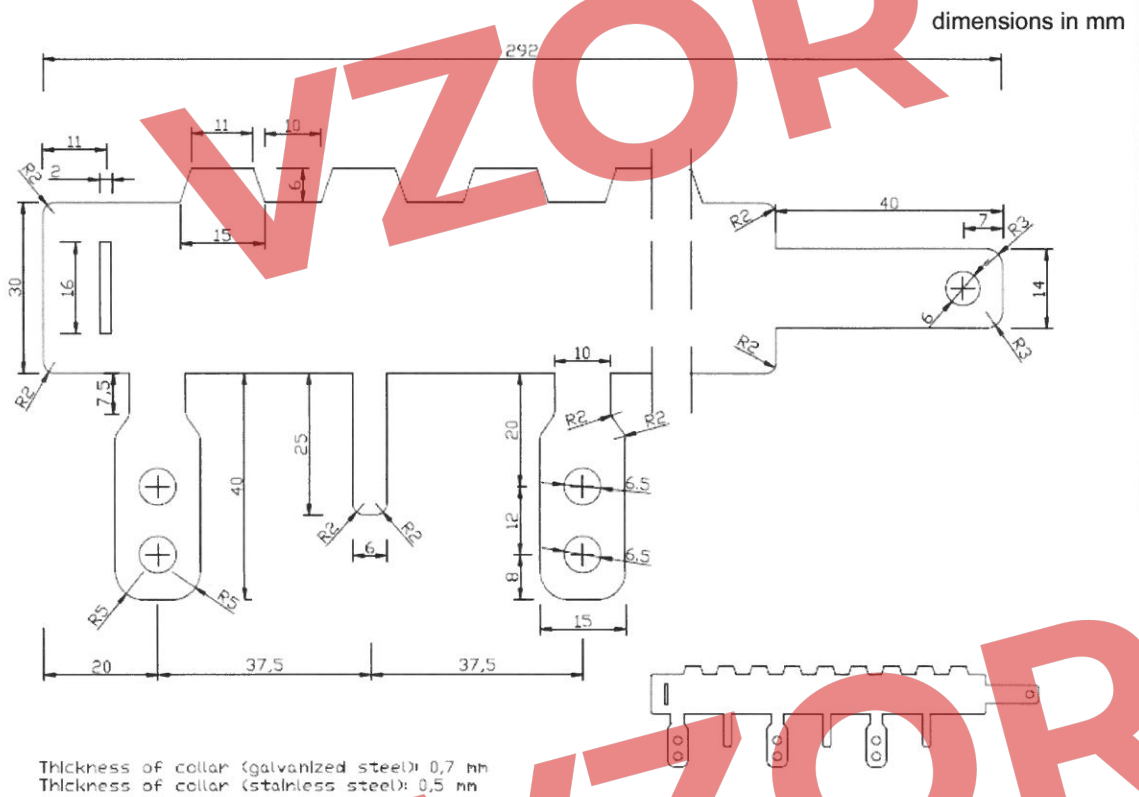

Fig. B2. Housing of PS Collar DN63

PS Collar and PS-25 Wrap	Annex B
Housing types of PS Collar	of European Technical Assessment ETA-17/0676

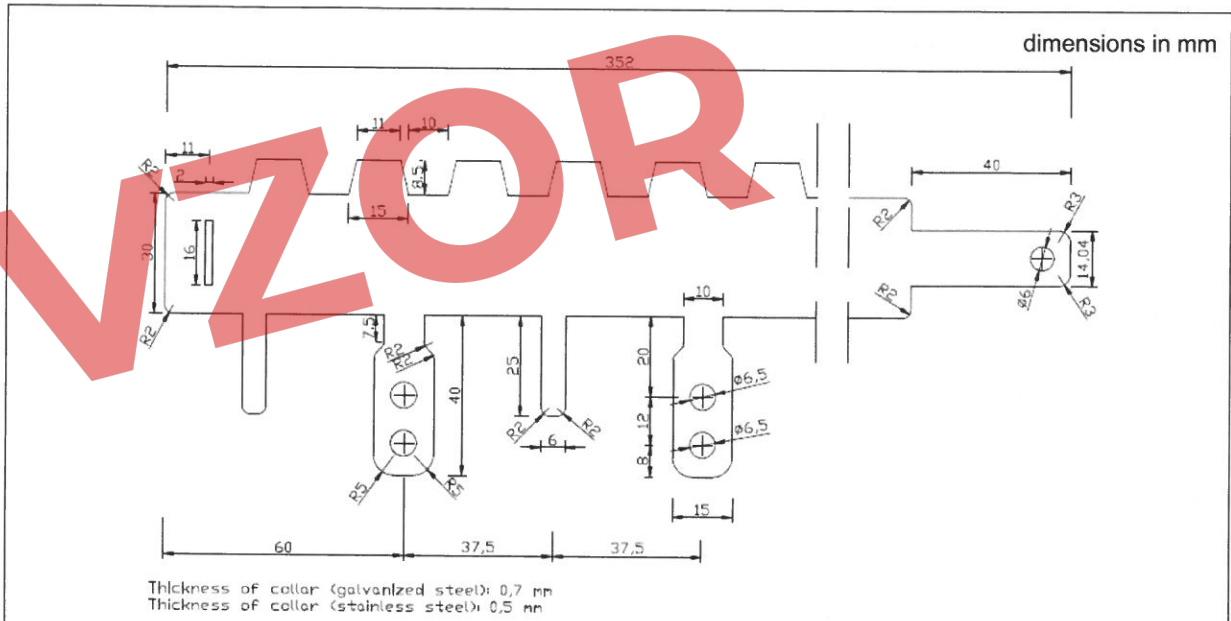

Fig. B3. Housing of PS Collar DN75

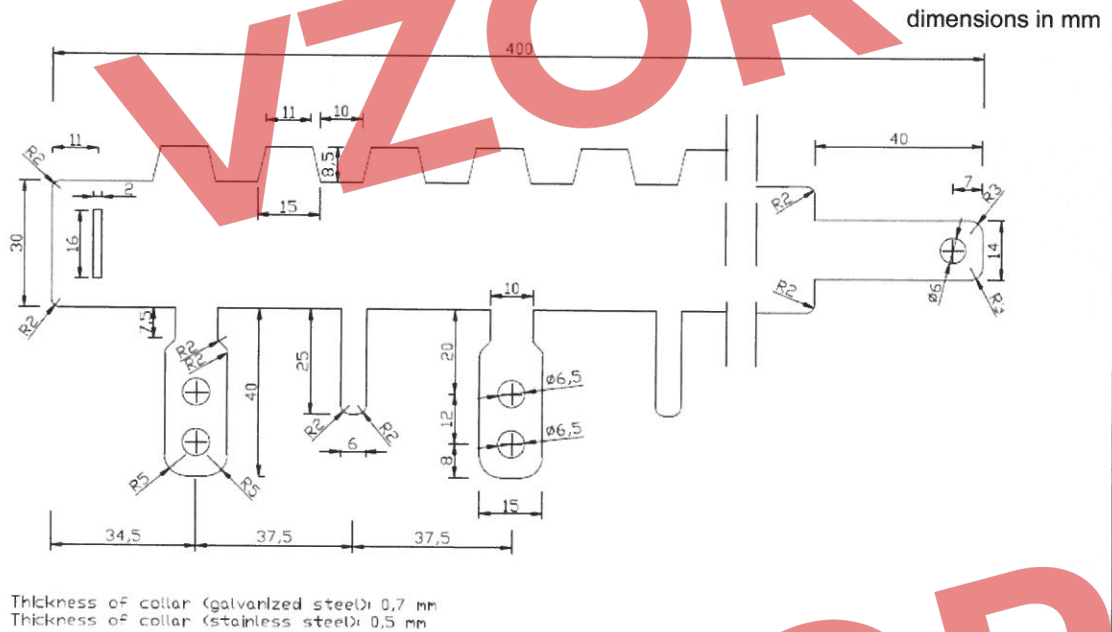

Fig. B4. Housing of PS Collar DN90

PS Collar and PS-25 Wrap	Annex B
Housing types of PS Collar	of European Technical Assessment ETA-17/0676

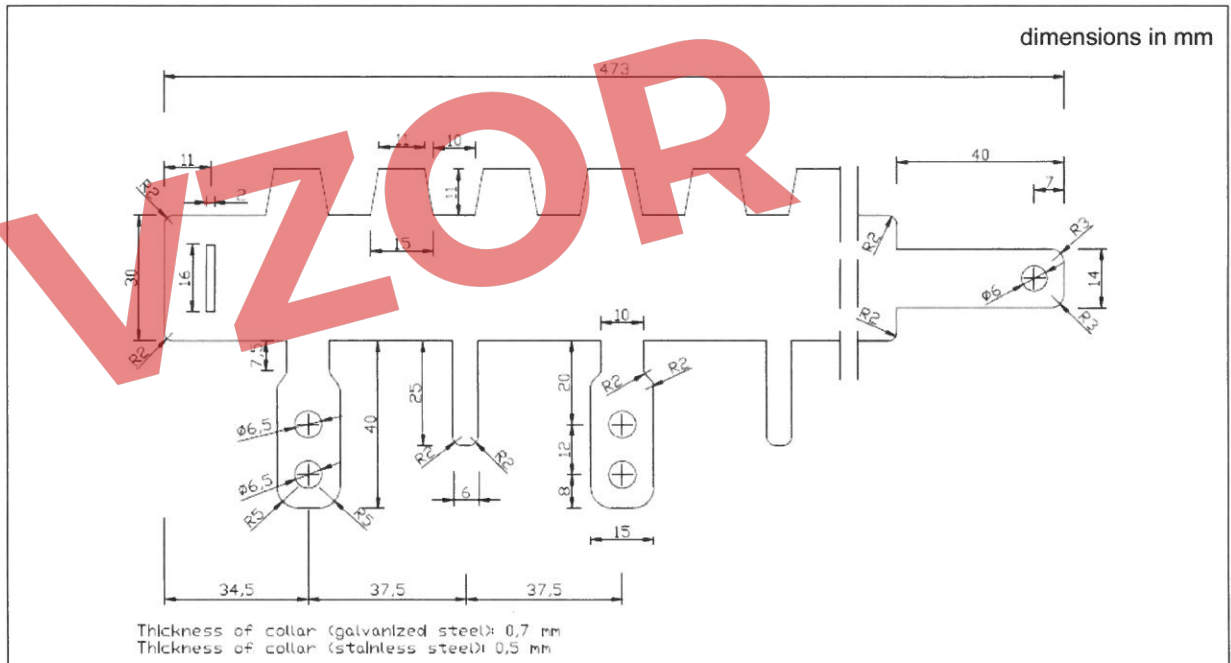

Fig. B5. Housing of PS Collar DN110

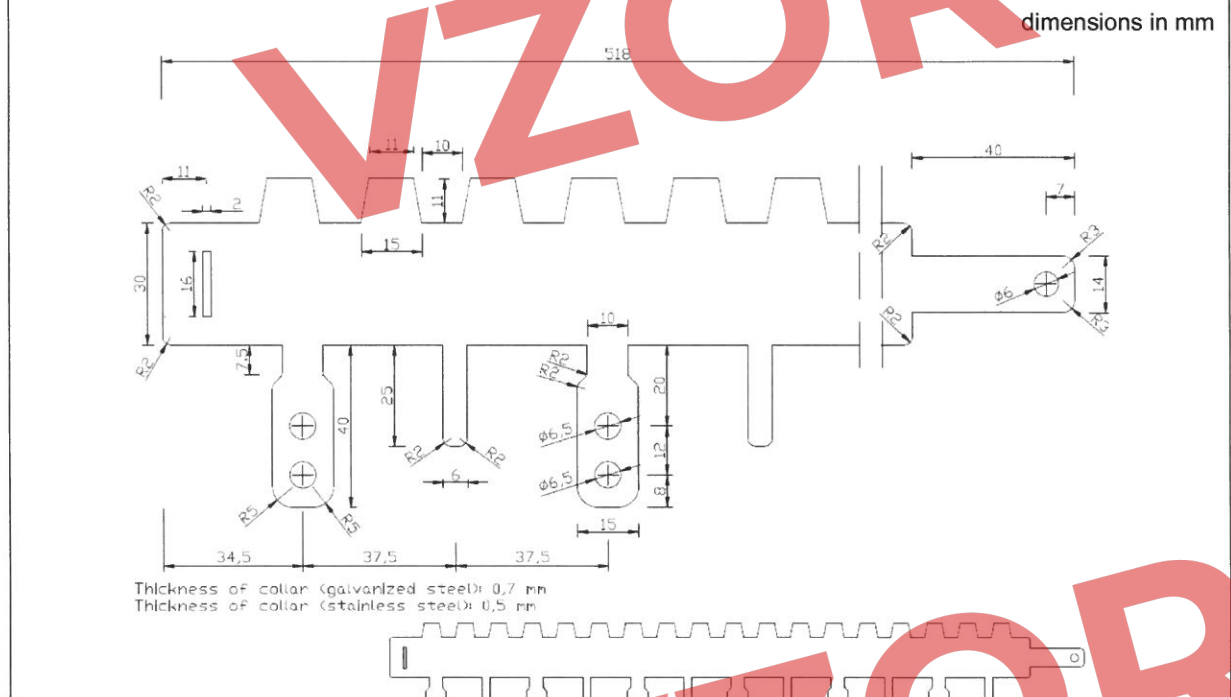

Fig. B6. Housing of PS Collar DN125

<p>PS Collar and PS-25 Wrap</p>	<p>Annex B</p>
<p>Housing types of PS Collar</p>	<p>of European Technical Assessment ETA-17/0676</p>

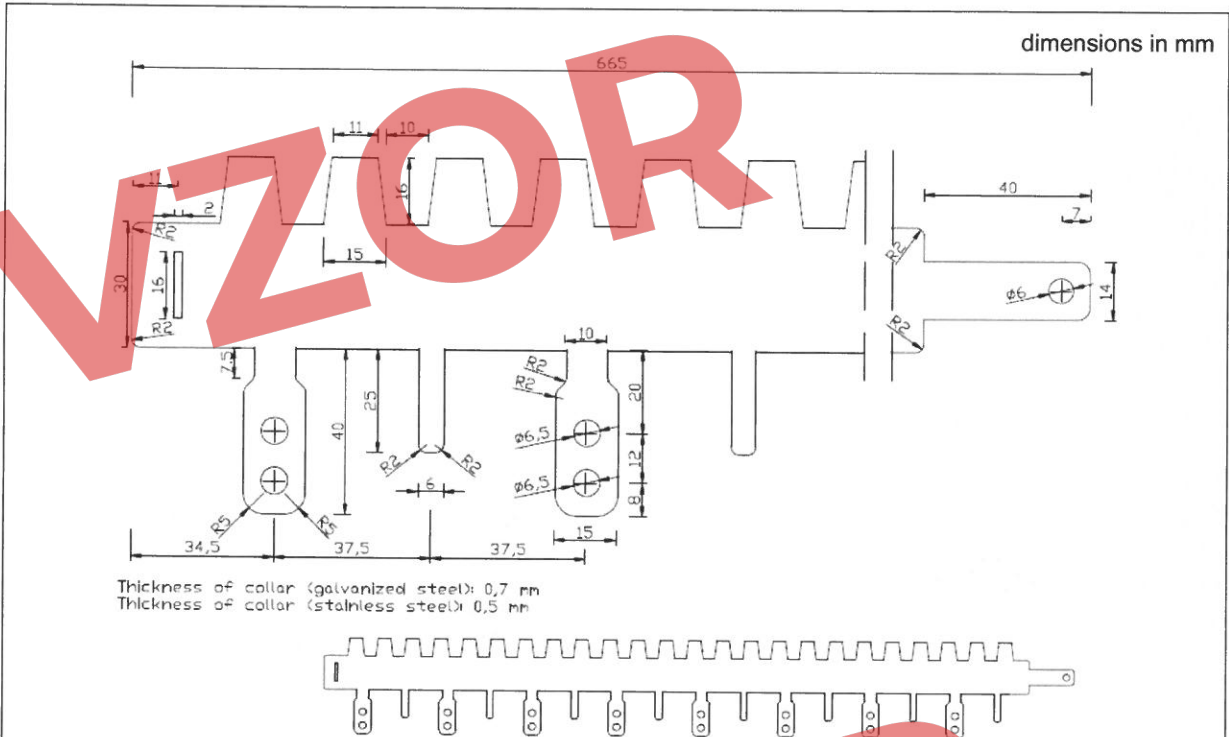

Fig. B7. Housing of PS Collar DN160

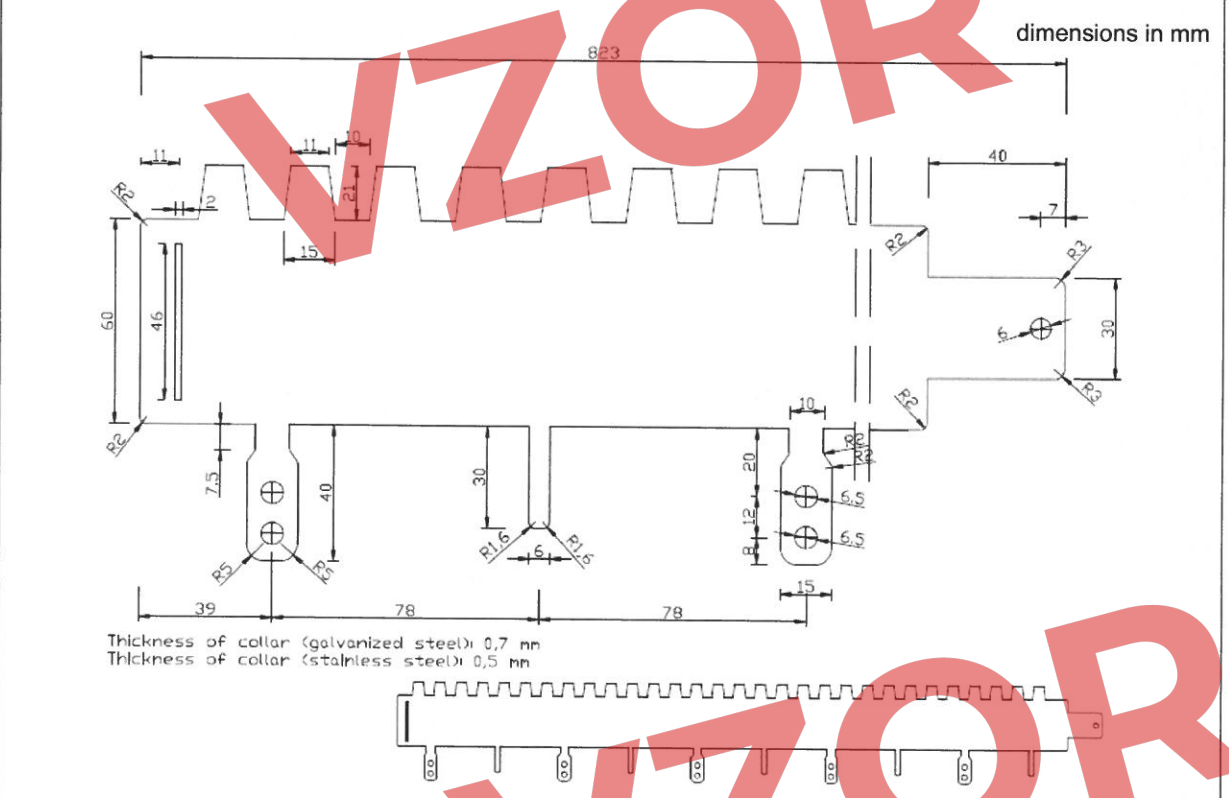

Fig. B8. Housing of PS Collar DN200

PS Collar and PS-25 Wrap	Annex B
Housing types of PS Collar	of European Technical Assessment ETA-17/0676

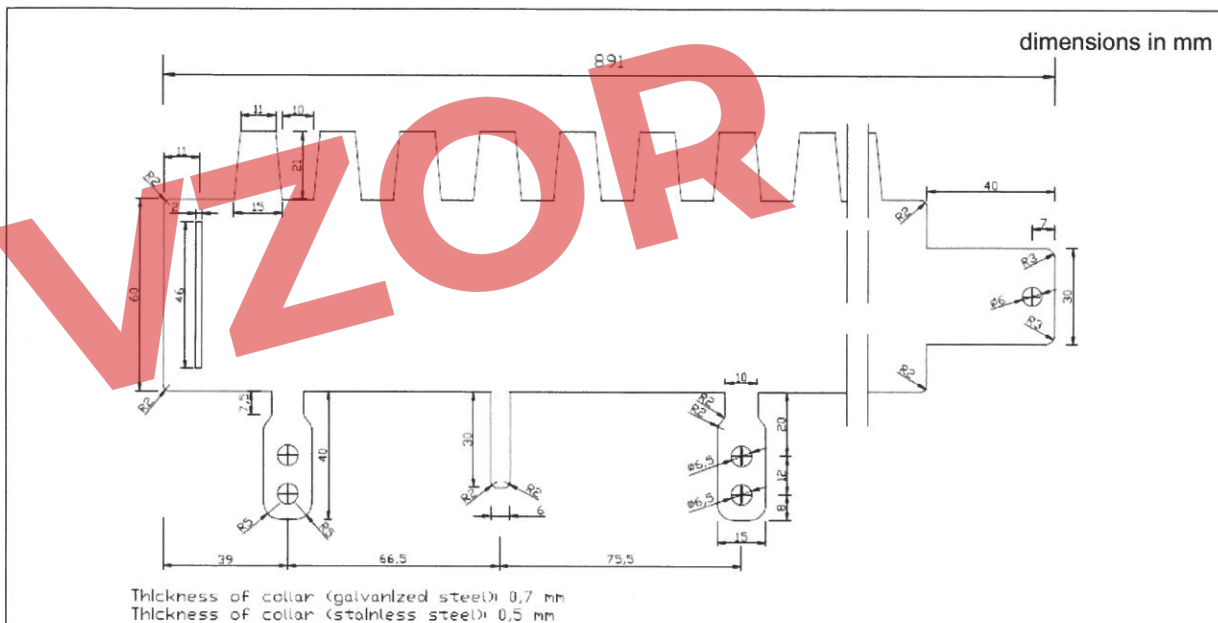

Fig. B9. Housing of PS Collar DN225

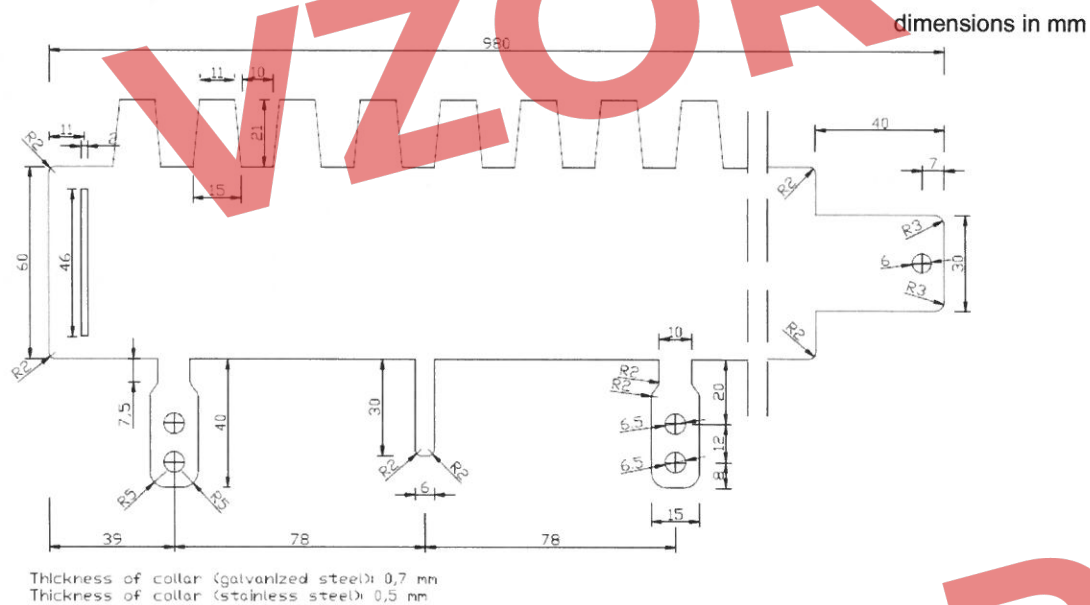
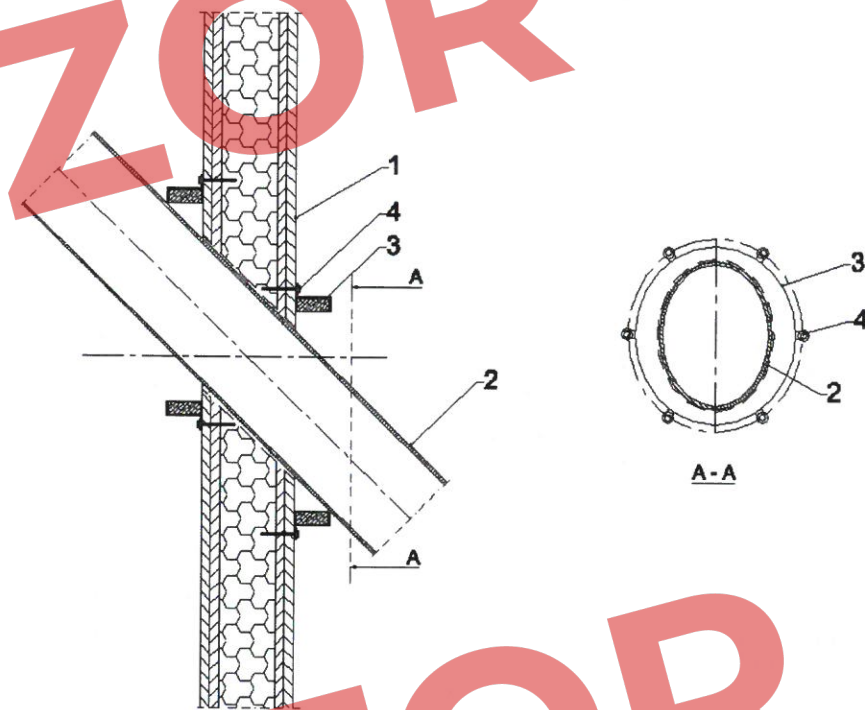

Fig. B10. Housing of PS Collar DN250

PS Collar and PS-25 Wrap	Annex B
Housing types of PS Collar	of European Technical Assessment ETA-17/0676

Plastic pipe penetration seal in flexible or rigid wall, made with use of PS Collar, placed in angle between 0° and 89° to the wall.



- 1 Flexible or rigid wall with thickness ≥ 100 mm
- 2 Plastic pipe
- 3 PS collar, fixed on both sides of the wall
- 4 Fastener M6x90, number of fasteners in accordance with Annex A

Resistance to fire classification of plastic pipes penetration seals in flexible or rigid wall, made with use of PS Collar, placed in angle between 0° and 89° to the wall:

Table C1.1 PVC-U / PVC-C pipes

Pipe material	Pipe diameter, [mm]	Pipe wall thickness, [mm]	Intumescent material		Fire resistance class
			width, [mm]	thickness, [mm]	
PVC-U / PVC-C	$\varnothing \leq 32$	1,8 – 3,4	30	5,0	EI 60 – U/C EI 60 – C/C
	$32 < \varnothing \leq 51$	2,2 – 4,1	30	7,5	
	$51 < \varnothing \leq 71$	2,5 – 4,9	30	10,0	
	$71 < \varnothing \leq 90$	2,9 – 5,7	30	12,5	
	$90 < \varnothing \leq 110$	3,2 – 6,5	30	15,0	
	$110 < \varnothing \leq 135$	3,2 – 5,6	60	17,5	
	$135 < \varnothing \leq 160$	3,2 – 4,7	60	20,0	

PS Collar and PS-25 Wrap

Annex C1

Construction details and resistance to fire classification of penetration seals made with use of PS Collar
Plastic pipe penetration seal in flexible or rigid wall

of European Technical Assessment
ETA-17/0676

Plastic pipes bundle penetration seal in flexible or rigid wall, made with use of PS Collar.

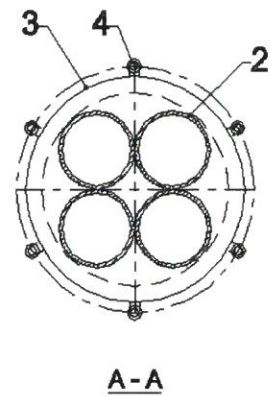
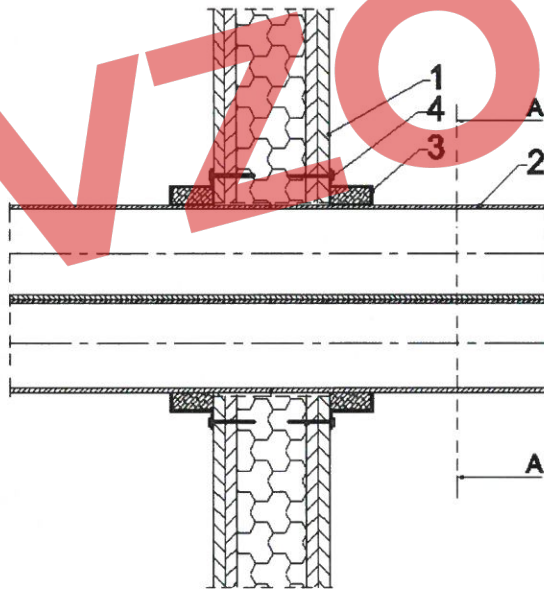

- 1 Flexible or rigid wall with thickness ≥ 100 mm
- 2 Plastic pipe (maximum 4 pipes in bundle)
- 3 PS collar, fixed on both sides of the wall
- 4 Fastener M6x90, number of fasteners in accordance with Annex A

Resistance to fire classification of plastic pipes bundle penetration seals in flexible or rigid wall, made with use of PS Collar:

Table C2.1 PP-R pipes (maximum 4 pipes in bundle)

Pipe material	Single pipe diameter, [mm]	Pipe wall thickness, [mm]	Intumescent material		Fire resistance class
			width, [mm]	thickness, [mm]	
PP-R	$\varnothing \leq 32$	2,9 – 5,4	30	7,5	EI 60 – U/C EI 60 – C/C
	$32 < \varnothing \leq 40$	3,5 – 5,4	60	10,0	
	$40 < \varnothing \leq 49$	4,1 – 5,5	60	12,5	
	$49 < \varnothing \leq 57$	4,6 – 5,6	60	15,0	
	$57 < \varnothing \leq 66$	5,2 – 5,7	60	17,5	
	$66 < \varnothing \leq 75$	5,8	60	20,0	

PS Collar and PS-25 Wrap	Annex C2
Construction details and resistance to fire classification of penetration seals made with use of PS Collar Plastic pipes bundle penetration seal in flexible or rigid wall	of European Technical Assessment ETA-17/0676

Plastic pipe penetration seal in flexible or rigid wall, made with use of PS Collar.

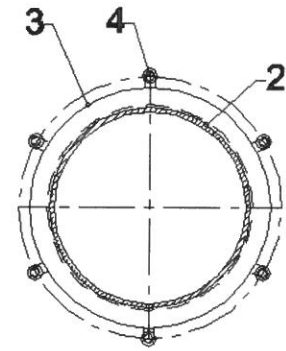
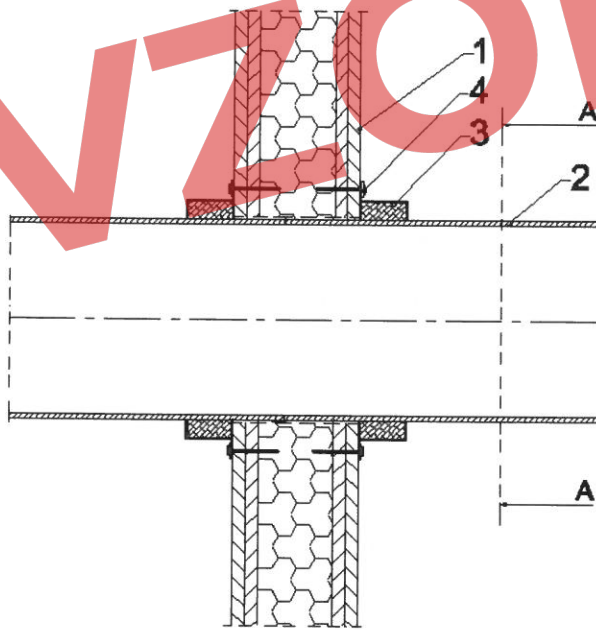

A-A

- 1 Flexible or rigid wall with thickness ≥ 100 mm
- 2 Plastic pipe
- 3 PS collar, fixed on both sides of the wall
- 4 Fastener M6x90, number of fasteners in accordance with Annex A

PS Collar and PS-25 Wrap

Annex C3

**Construction details of penetration seals
made with use of PS Collar**
Plastic pipe penetration seal in flexible or rigid wall

of European
Technical Assessment
ETA-17/0676

Resistance to fire classification of plastic pipes penetration seals in flexible or rigid wall, made with use of PS Collar, in accordance with Annex C3:

Table C4.1 PE-HD pipes

Pipe material	Pipe diameter, [mm]	Pipe wall thickness, [mm]	Intumescent material		Fire resistance class
			width, [mm]	thickness, [mm]	
PE-HD	$\varnothing \leq 63$	3,0 – 5,8	30	5,0	EI 60 – U/C EI 60 – C/C
	$63 < \varnothing \leq 87$	3,8 – 7,9	30	7,5	
	$87 < \varnothing \leq 111$	4,6 – 10,1	30	10,0	
	$111 < \varnothing \leq 135$	5,4 – 12,3	30	12,5	
	$135 < \varnothing \leq 160$	6,2 – 14,6	30	15,0	
	$160 < \varnothing \leq 205$	7,9 – 14,6	60	17,5	
	$205 < \varnothing \leq 250$	9,6 – 14,6	60	20,0	

Table C4.2 PP-R pipes

Pipe material	Pipe diameter, [mm]	Pipe wall thickness, [mm]	Intumescent material		Fire resistance class
			width, [mm]	thickness, [mm]	
PP-R	$\varnothing \leq 63$	5,8	30	5,0	EI 60 – U/C EI 60 – C/C
		5,9 – 7,9	30	7,5	
	$63 < \varnothing \leq 87$	5,8 – 7,9	30	7,5	
	$87 < \varnothing \leq 111$	5,8 – 10,1	30	10,0	
	$111 < \varnothing \leq 135$	5,7 – 12,3	30	12,5	
	$135 < \varnothing \leq 160$	5,6 – 14,6	30	15,0	

Table C4.3 PVC-U / PVC-C pipes

Pipe material	Pipe diameter, [mm]	Pipe wall thickness, [mm]	Intumescent material		Fire resistance class
			width, [mm]	thickness, [mm]	
PVC-U / PVC-C	$\varnothing \leq 63$	2,0 – 5,1	30	5,0	EI 60 – U/C EI 60 – C/C
	$63 < \varnothing \leq 87$	2,3 – 5,0	30	7,5	
	$87 < \varnothing \leq 111$	2,6 – 4,9	30	10,0	
	$111 < \varnothing \leq 135$	2,9 – 4,8	30	12,5	
	$135 < \varnothing \leq 160$	3,2 – 4,7	30	15,0	
	$160 < \varnothing \leq 205$	4,7 – 8,5	60	17,5	
	$205 < \varnothing \leq 250$	6,2 – 9,6	60	20,0	

PS Collar and PS-25 Wrap

Annex C4

Resistance to fire classification of penetration seals made with use of PS Collar

Plastic pipe penetration seal in flexible or rigid wall

of European
Technical Assessment
ETA-17/0676

Plastic pipe penetration seal in flexible or rigid wall, made with use of PS Collar, placed in angle between 0° and 89° to the wall.

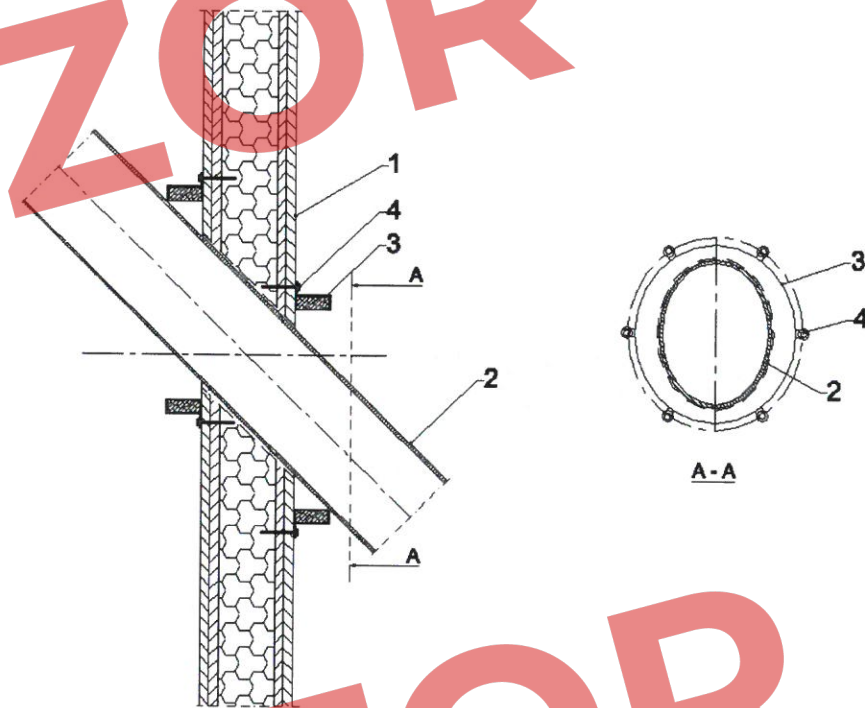

- 1 Flexible or rigid wall with thickness ≥ 100 mm
- 2 Plastic pipe
- 3 PS collar, fixed on both sides of the wall
- 4 Fastener M6x90, number of fasteners in accordance with Annex A

Resistance to fire classification of plastic pipes penetration seals in flexible or rigid wall, made with use of PS Collar, placed in angle between 0° and 89° to the wall:

Table C5.1 PVC-U / PVC-C pipes

Pipe material	Pipe diameter, [mm]	Pipe wall thickness, [mm]	Intumescent material		Fire resistance class
			width, [mm]	thickness, [mm]	
PVC-U / PVC-C	$\varnothing \leq 32$	3,4	30	5,0	EI 90 – U/C EI 90 – C/C
	$32 < \varnothing \leq 51$	3,4 – 4,1	30	7,5	
	$51 < \varnothing \leq 71$	3,3 – 4,9	30	10,0	
	$71 < \varnothing \leq 90$	3,3 – 5,7	30	12,5	
	$90 < \varnothing \leq 110$	3,2 – 6,5	30	15,0	
	$110 < \varnothing \leq 135$	3,2 – 5,6	60	17,5	
	$135 < \varnothing \leq 160$	3,2 – 4,7	60	20,0	

PS Collar and PS-25 Wrap

Annex C5

Construction details and resistance to fire classification of penetration seals made with use of PS Collar
Plastic pipe penetration seal in flexible or rigid wall

of European Technical Assessment
ETA-17/0676

Plastic pipes bundle penetration seal in flexible or rigid wall, made with use of PS Collar.

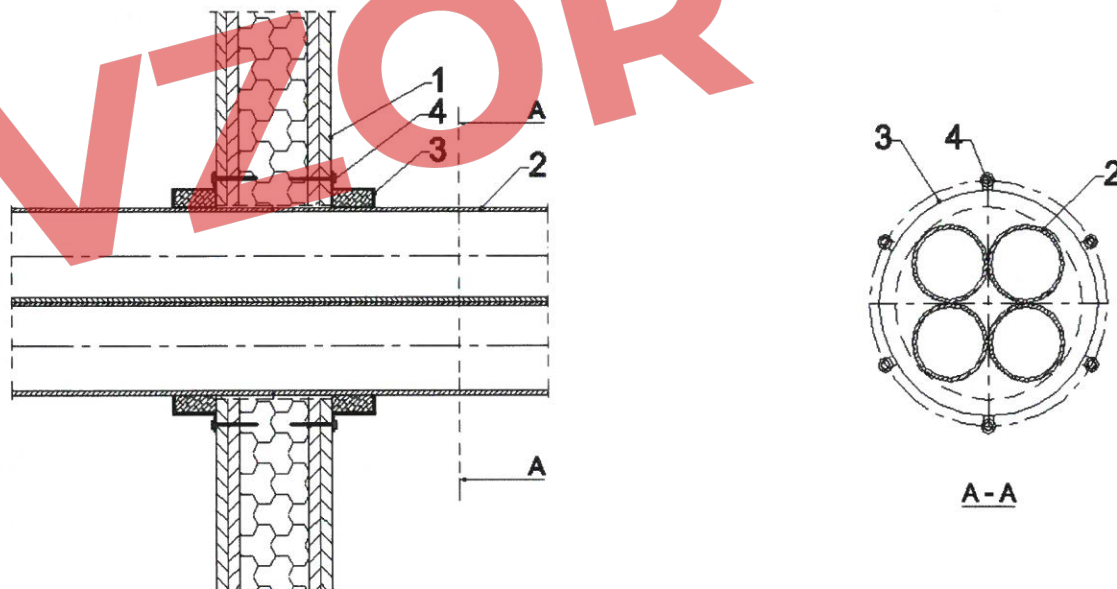

- 1 Flexible or rigid wall with thickness ≥ 100 mm
- 2 Plastic pipe (maximum 4 pipes in bundle)
- 3 PS collar, fixed on both sides of the wall
- 4 Fastener M6x90, number of fasteners in accordance with Annex A

Resistance to fire classification of plastic pipes bundle penetration seals in flexible or rigid wall, made with use of PS Collar:

Table C6.1 PP-R pipes (maximum 4 pipes in bundle)

Pipe material	Single pipe diameter, [mm]	Pipe wall thickness, [mm]	Intumescent material		Fire resistance class
			width, [mm]	thickness, [mm]	
PP-R	$\varnothing \leq 32$	2,9 – 5,4	30	7,5	EI 90 – U/C EI 90 – C/C
	$32 < \varnothing \leq 40$	3,5 – 5,4	60	10,0	
	$40 < \varnothing \leq 49$	4,1 – 5,5	60	12,5	
	$49 < \varnothing \leq 57$	4,6 – 5,6	60	15,0	
	$57 < \varnothing \leq 66$	5,2 – 5,7	60	17,5	
	$66 < \varnothing \leq 75$	5,8	60	20,0	

PS Collar and PS-25 Wrap

Annex C6

Construction details and resistance to fire classification of penetration seals made with use of PS Collar
Plastic pipes bundle penetration seal in flexible or rigid wall

of European
Technical Assessment
ETA-17/0676

Plastic pipe penetration seal in flexible or rigid wall, made with use of PS Collar.

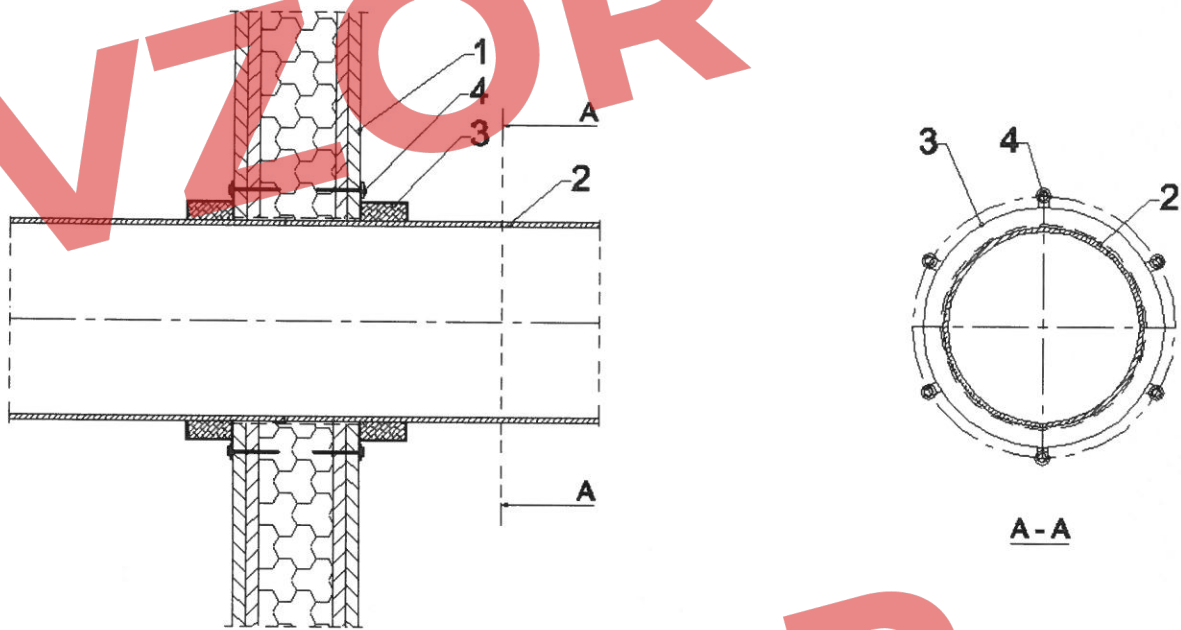

- 1 Flexible or rigid wall with thickness ≥ 100 mm
- 2 Plastic pipe
- 3 PS collar, fixed on both sides of the wall
- 4 Fastener M6x90, number of fasteners in accordance with Annex A

PS Collar and PS-25 Wrap

Annex C7

**Construction details of penetration seals
made with use of PS Collar**
Plastic pipe penetration seal in flexible or rigid wall

of European
Technical Assessment
ETA-17/0676

Resistance to fire classification of plastic pipes penetration seals in flexible or rigid wall, made with use of PS Collar, in accordance with Annex C7:

Table C8.1 PE-HD pipes

Pipe material	Pipe diameter, [mm]	Pipe wall thickness, [mm]	Intumescent material		Fire resistance class
			width, [mm]	thickness, [mm]	
PE-HD	$\varnothing \leq 63$	3,0 – 5,8	30	5,0	EI 90 – U/C EI 90 – C/C
	$63 < \varnothing \leq 87$	3,8 – 7,9	30	7,5	
	$87 < \varnothing \leq 111$	4,6 – 10,1	30	10,0	
	$111 < \varnothing \leq 135$	5,4 – 12,3	30	12,5	
	$135 < \varnothing \leq 160$	6,2 – 14,6	30	15,0	
	$160 < \varnothing \leq 205$	7,9 – 14,6	60	17,5	
	$205 < \varnothing \leq 250$	9,6 – 14,6	60	20,0	

Table C8.2 PP-R pipes

Pipe material	Pipe diameter, [mm]	Pipe wall thickness, [mm]	Intumescent material		Fire resistance class
			width, [mm]	thickness, [mm]	
PP-R	$\varnothing \leq 63$	5,8	30	5,0	EI 90 – U/C EI 90 – C/C
		5,9 – 7,9	30	7,5	
	$63 < \varnothing \leq 87$	5,8 – 7,9	30	7,5	
	$87 < \varnothing \leq 111$	5,8 – 10,1	30	10,0	
	$111 < \varnothing \leq 135$	5,7 – 12,3	30	12,5	
	$135 < \varnothing \leq 160$	5,6 – 14,6	30	15,0	

Table C8.3 PVC-U / PVC-C pipes

Pipe material	Pipe diameter, [mm]	Pipe wall thickness, [mm]	Intumescent material		Fire resistance class
			width, [mm]	thickness, [mm]	
PVC-U / PVC-C	$\varnothing \leq 63$	2,0 – 5,1	30	5,0	EI 90 – U/C EI 90 – C/C
	$63 < \varnothing \leq 87$	2,3 – 5,0	30	7,5	
	$87 < \varnothing \leq 111$	2,6 – 4,9	30	10,0	
	$111 < \varnothing \leq 135$	2,9 – 4,8	30	12,5	
	$135 < \varnothing \leq 160$	3,2 – 4,7	30	15,0	
	$160 < \varnothing \leq 205$	4,7 – 8,5	60	17,5	
	$205 < \varnothing \leq 250$	6,2 – 9,6	60	20,0	

PS Collar and PS-25 Wrap

Resistance to fire classification of penetration seals made with use of PS Collar

Plastic pipe penetration seal in flexible or rigid wall

Annex C8

of European
Technical Assessment
ETA-17/0676

Plastic pipe penetration seal in flexible or rigid wall, made with use of PS Collar, placed in angle between 0° and 89° to the wall.

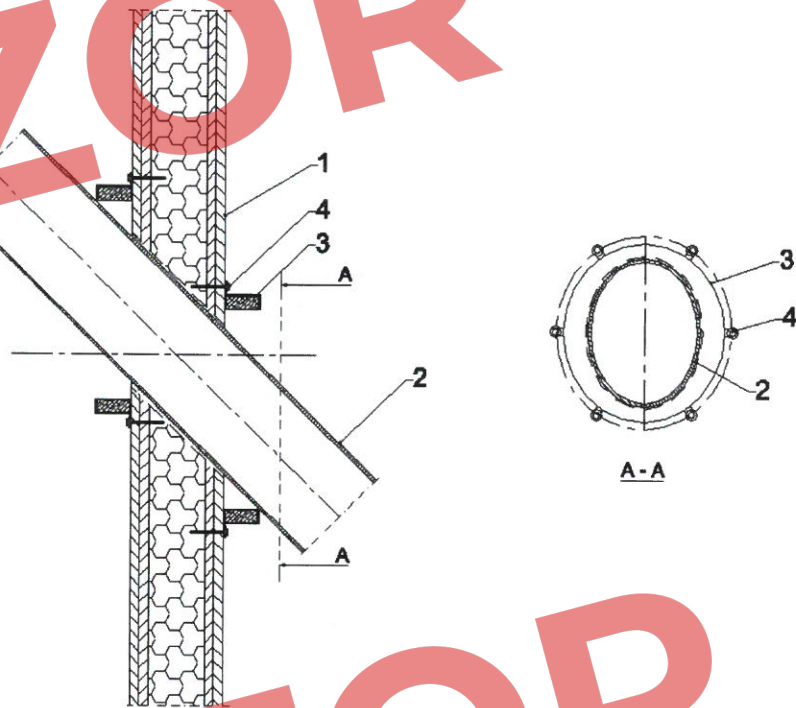

- 1 Flexible or rigid wall with thickness ≥ 100 mm
- 2 Plastic pipe
- 3 PS collar, fixed on both sides of the wall
- 4 Fastener M6x90, number of fasteners in accordance with Annex A

Resistance to fire classification of plastic pipes penetration seals in flexible or rigid wall, made with use of PS Collar, placed in angle between 0° and 89° to the wall:

Table C9.1 PVC-U / PVC-C pipes

Pipe material	Pipe diameter, [mm]	Pipe wall thickness, [mm]	Intumescent material		Fire resistance class
			width, [mm]	thickness, [mm]	
PVC-U / PVC-C	$\varnothing \leq 32$	3,4	30	5,0	EI 120 – U/C EI 120 – C/C
	$32 < \varnothing \leq 51$	3,4 – 4,1	30	7,5	
	$51 < \varnothing \leq 71$	3,3 – 4,9	30	10,0	
	$71 < \varnothing \leq 90$	3,3 – 5,7	30	12,5	
	$90 < \varnothing \leq 110$	3,2 – 6,5	30	15,0	
	$110 < \varnothing \leq 135$	3,2 – 5,6	60	17,5	
	$135 < \varnothing \leq 160$	3,2 – 4,7	60	20,0	

PS Collar and PS-25 Wrap

Annex C9

Construction details and resistance to fire classification of penetration seals made with use of PS Collar
Plastic pipe penetration seal in flexible or rigid wall

of European
Technical Assessment
ETA-17/0676

Plastic pipes bundle penetration seal in flexible or rigid wall, made with use of PS Collar.

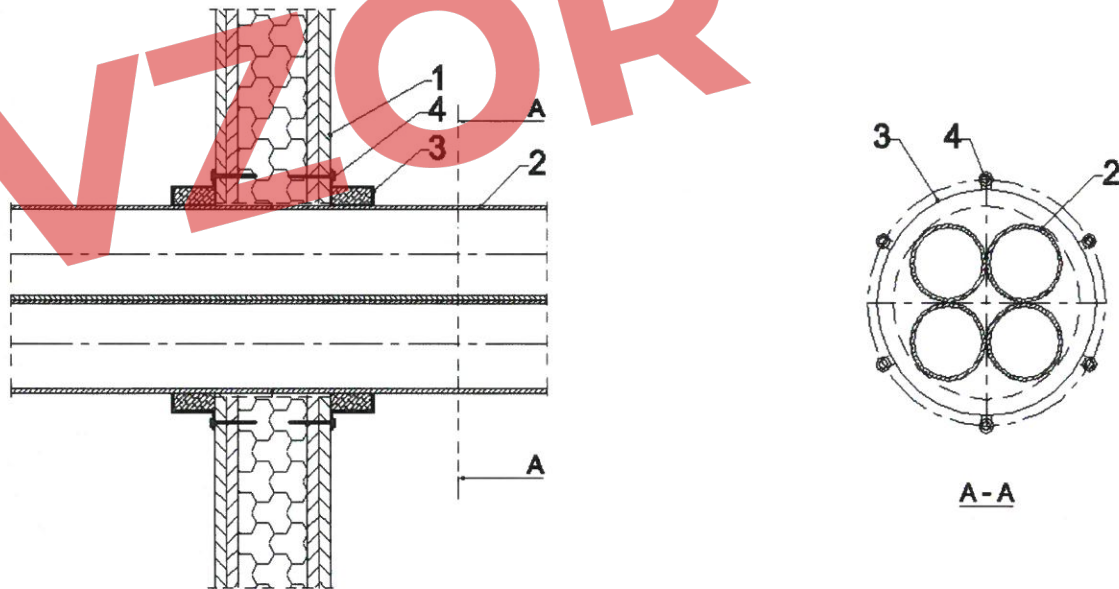

- 1 Flexible or rigid wall with thickness ≥ 100 mm
- 2 Plastic pipe (maximum 4 pipes in bundle)
- 3 PS collar, fixed on both sides of the wall
- 4 Fastener M6x90, number of fasteners in accordance with Annex A

Resistance to fire classification of plastic pipes bundle penetration seals in flexible or rigid wall, made with use of PS Collar:

Table C10.1 PP-R pipes (maximum 4 pipes in bundle)

Pipe material	Single pipe diameter, [mm]	Pipe wall thickness, [mm]	Intumescent material		Fire resistance class
			width, [mm]	thickness, [mm]	
PP-R	$\varnothing \leq 32$	2,9 – 5,4	30	7,5	EI 120 – U/C EI 120 – C/C
	$32 < \varnothing \leq 40$	3,5 – 5,4	60	10,0	
	$40 < \varnothing \leq 49$	4,1 – 5,5	60	12,5	
	$49 < \varnothing \leq 57$	4,6 – 5,6	60	15,0	
	$57 < \varnothing \leq 66$	5,2 – 5,7	60	17,5	
	$66 < \varnothing \leq 75$	5,8	60	20,0	

PS Collar and PS-25 Wrap

Annex C10

Construction details and resistance to fire classification of penetration seals made with use of PS Collar
Plastic pipes bundle penetration seal in flexible or rigid wall

of European
Technical Assessment
ETA-17/0676

Plastic pipe penetration seal in flexible or rigid wall, made with use of PS Collar.

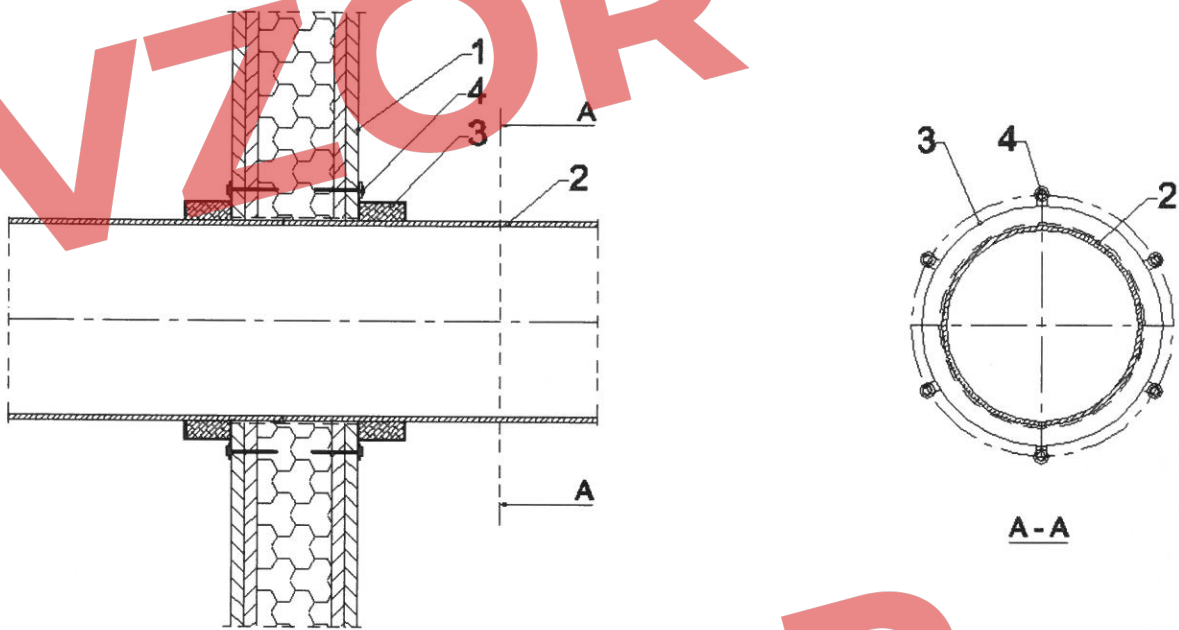

- 1 Flexible or rigid wall with thickness ≥ 100 mm
- 2 Plastic pipe
- 3 PS collar, fixed on both sides of the wall
- 4 Fastener M6x90, number of fasteners in accordance with Annex A

PS Collar and PS-25 Wrap

Annex C11

**Construction details of penetration seals
made with use of PS Collar**
Plastic pipe penetration seal in flexible or rigid wall

of European
Technical Assessment
ETA-17/0676

Resistance to fire classification of plastic pipe penetration seals in flexible or rigid wall, made with use of PS Collar, in accordance with Annex C11:

Table C12.1 PE-HD pipes

Pipe material	Pipe diameter, [mm]	Pipe wall thickness, [mm]	Intumescent material		Fire resistance class
			width, [mm]	thickness, [mm]	
PE-HD	$\varnothing \leq 63$	3,0 – 5,8	30	5,0	EI 120 – U/C EI 120 – C/C
	$63 < \varnothing \leq 87$	3,8 – 5,9	30	7,5	
	$87 < \varnothing \leq 111$	4,6 – 6,0	30	10,0	
	$111 < \varnothing \leq 135$	5,4 – 6,1	30	12,5	
	$135 < \varnothing \leq 160$	6,2	30	15,0	

Table C12.2 PP-R pipes

Pipe material	Pipe diameter, [mm]	Pipe wall thickness, [mm]	Intumescent material		Fire resistance class
			width, [mm]	thickness, [mm]	
PP-R	$\varnothing \leq 63$	5,8	30	5,0	EI 120 – U/C EI 120 – C/C
		5,9 – 7,9	30	7,5	
	$63 < \varnothing \leq 87$	5,8 – 7,9	30	7,5	
	$87 < \varnothing \leq 111$	5,8 – 10,1	30	10,0	
	$111 < \varnothing \leq 135$	5,7 – 12,3	30	12,5	
	$135 < \varnothing \leq 160$	5,6 – 14,6	30	15,0	

Table C12.3 PVC-U / PVC-C pipes

Pipe material	Pipe diameter, [mm]	Pipe wall thickness, [mm]	Intumescent material		Fire resistance class
			width, [mm]	thickness, [mm]	
PVC-U / PVC-C	$\varnothing \leq 63$	2,0 – 5,1	30	5,0	EI 120 – U/C EI 120 – C/C
	$63 < \varnothing \leq 87$	2,3 – 5,0	30	7,5	
	$87 < \varnothing \leq 111$	2,6 – 4,9	30	10,0	
	$111 < \varnothing \leq 135$	2,9 – 4,8	30	12,5	
	$135 < \varnothing \leq 160$	3,2 – 4,7	30	15,0	
	$160 < \varnothing \leq 205$	4,7 – 8,5	60	17,5	
	$205 < \varnothing \leq 250$	6,2 – 9,6	60	20,0	

PS Collar and PS-25 Wrap

Annex C12

Resistance to fire classification of penetration seals made with use of PS Collar

Plastic pipe penetration seal in flexible or rigid wall

of European
Technical Assessment
ETA-17/0676

Plastic pipe penetration seal in rigid floor, made with use of PS Collar, placed in angle between 0° and 89° to the floor.

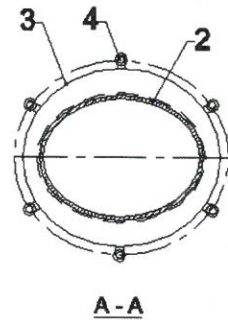
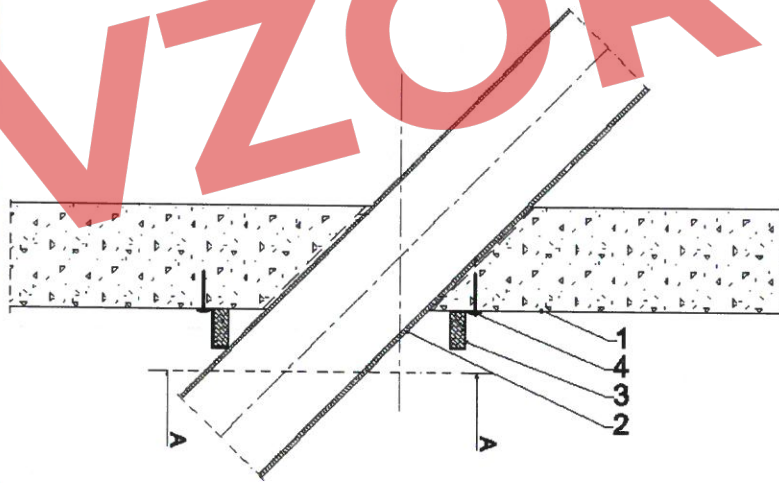

- 1 Rigid floor with thickness ≥ 150 mm and density ≥ 600 kg/m³
- 2 Plastic pipe
- 3 PS collar, fixed at the bottom of the floor
- 4 Fastener M6x60, number of fasteners in accordance with Annex A

Resistance to fire classification of plastic pipes penetration seals in rigid floor, made with use of PS Collar, placed in angle between 0° and 89° to the floor:

Table C13.1 PVC-U / PVC-C pipes

Pipe material	Pipe diameter, [mm]	Pipe wall thickness, [mm]	Intumescent material		Fire resistance class
			width, [mm]	thickness, [mm]	
PVC-U / PVC-C	$\varnothing \leq 32$	1,8 – 3,4	30	5,0	EI 90 – U/C EI 90 – C/C
	$32 < \varnothing \leq 51$	2,2 – 4,1	30	7,5	
	$51 < \varnothing \leq 71$	2,5 – 4,9	30	10,0	
	$71 < \varnothing \leq 90$	2,9 – 5,7	30	12,5	
	$90 < \varnothing \leq 110$	3,2 – 6,5	30	15,0	
	$110 < \varnothing \leq 135$	3,2 – 5,6	60	17,5	
	$135 < \varnothing \leq 160$	3,2 – 4,7	60	20,0	

PS Collar and PS-25 Wrap

Annex C13

Construction details and resistance to fire classification of penetration seals made with use of PS Collar
Plastic pipe penetration seal in rigid floor

of European Technical Assessment
ETA-17/0676

Plastic pipes bundle penetration seal in rigid floor, made with use of PS Collar.

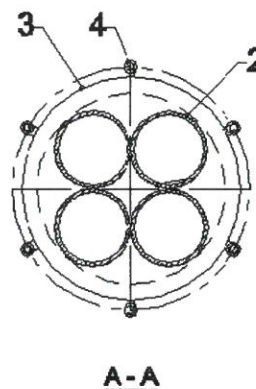
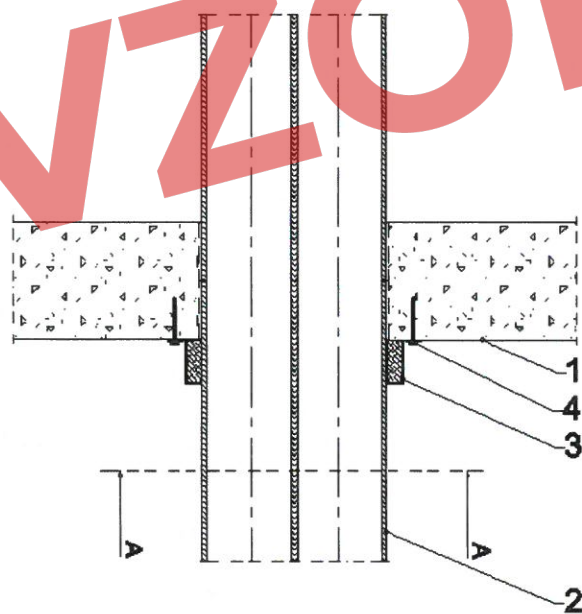

- 1 Rigid floor with thickness ≥ 150 mm and density ≥ 600 kg/m³
- 2 Plastic pipe (maximum 4 pipes in bundle)
- 3 PS collar, fixed at the bottom of the floor
- 4 Fastener M6x60, number of fasteners in accordance with Annex A

Resistance to fire classification of plastic pipes bundle penetration seals in rigid floor, made with use of PS Collar:

Table C14.1 PP-R pipes (maximum 4 pipes in bundle)

Pipe material	Single pipe diameter, [mm]	Pipe wall thickness, [mm]	Intumescent material		Fire resistance class
			width, [mm]	thickness, [mm]	
PP-R	$\varnothing \leq 32$	2,9 – 5,4	30	7,5	EI 90 – U/C EI 90 – C/C
	$32 < \varnothing \leq 40$	3,5 – 6,7	60	10,0	
	$40 < \varnothing \leq 49$	4,1 – 8,2	60	12,5	
	$49 < \varnothing \leq 57$	4,6 – 9,5	60	15,0	
	$57 < \varnothing \leq 66$	5,2 – 11,0	60	17,5	
	$66 < \varnothing \leq 75$	5,8 – 12,5	60	20,0	

PS Collar and PS-25 Wrap

Annex C14

Construction details and resistance to fire classification of penetration seals made with use of PS Collar
Plastic pipes bundle penetration seal in rigid floor

of European
Technical Assessment
ETA-17/0676

Plastic pipe penetration seal in rigid floor, made with use of PS Collar.

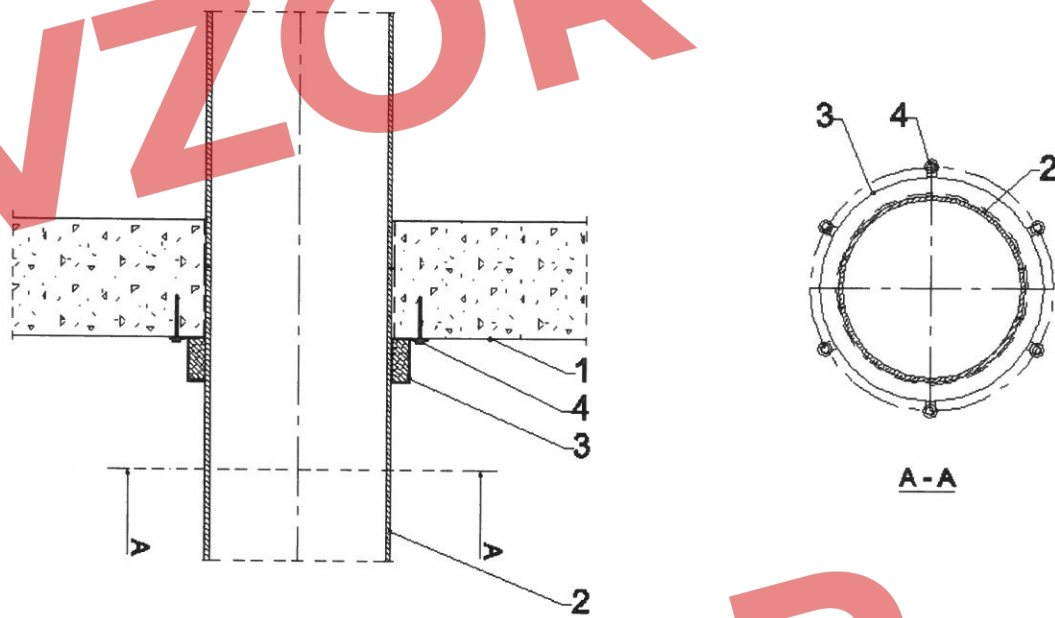

- 1 Rigid floor with thickness ≥ 150 mm and density ≥ 600 kg/m³
- 2 Plastic pipe
- 3 PS collar, fixed at the bottom of the floor
- 4 Fastener M6x60, number of fasteners in accordance with Annex A

PS Collar and PS-25 Wrap

Construction details of penetration seals
made with use of PS Collar
Plastic pipe penetration seal in rigid floor

Annex C15

of European
Technical Assessment
ETA-17/0676

Resistance to fire classification of plastic pipes penetration seals in rigid floor, made with use of PS Collar, in accordance with Annex C15:

Table C16.1 PE-HD pipes

Pipe material	Pipe diameter, [mm]	Pipe wall thickness, [mm]	Intumescent material		Fire resistance class
			width, [mm]	thickness, [mm]	
PE-HD	$\varnothing \leq 63$	3,0 – 5,8	30	5,0	EI 90 – U/C EI 90 – C/C
	$63 < \varnothing \leq 87$	3,8 – 7,9	30	7,5	
	$87 < \varnothing \leq 111$	4,6 – 10,1	30	10,0	
	$111 < \varnothing \leq 135$	5,4 – 12,3	30	12,5	
	$135 < \varnothing \leq 160$	6,2 – 14,6	30	15,0	
	$160 < \varnothing \leq 205$	7,9 – 14,6	60	17,5	
	$205 < \varnothing \leq 250$	9,6 – 14,6	60	20,0	

Table C16.2 PP-R pipes

Pipe material	Pipe diameter, [mm]	Pipe wall thickness, [mm]	Intumescent material		Fire resistance class
			width, [mm]	thickness, [mm]	
PP-R	$\varnothing \leq 63$	5,8 – 10,5	30	5,0	EI 90 – U/C EI 90 – C/C
	$63 < \varnothing \leq 87$	5,8 – 11,5	30	7,5	
	$87 < \varnothing \leq 111$	5,8 – 12,5	30	10,0	
	$111 < \varnothing \leq 135$	5,7 – 13,5	30	12,5	
	$135 < \varnothing \leq 160$	5,6 – 14,6	30	15,0	

Table C16.3 PVC-U / PVC-C pipes

Pipe material	Pipe diameter, [mm]	Pipe wall thickness, [mm]	Intumescent material		Fire resistance class
			width, [mm]	thickness, [mm]	
PVC-U / PVC-C	$\varnothing \leq 63$	2,0 – 5,1	30	5,0	EI 90 – U/C EI 90 – C/C
	$63 < \varnothing \leq 87$	2,3 – 5,0	30	7,5	
	$87 < \varnothing \leq 111$	2,6 – 4,9	30	10,0	
	$111 < \varnothing \leq 135$	2,9 – 4,8	30	12,5	
	$135 < \varnothing \leq 160$	3,2 – 4,7	30	15,0	
	$160 < \varnothing \leq 205$	4,7 – 8,5	60	17,5	
	$205 < \varnothing \leq 250$	6,2 – 9,6	60	20,0	

PS Collar and PS-25 Wrap

Resistance to fire classification of penetration seals made with use of PS Collar
Plastic pipe penetration seal in rigid floor

Annex C16

of European
Technical Assessment
ETA-17/0676

Plastic pipe penetration seal in rigid floor, made with use of PS Collar – pipe elbow on the bottom of the floor.

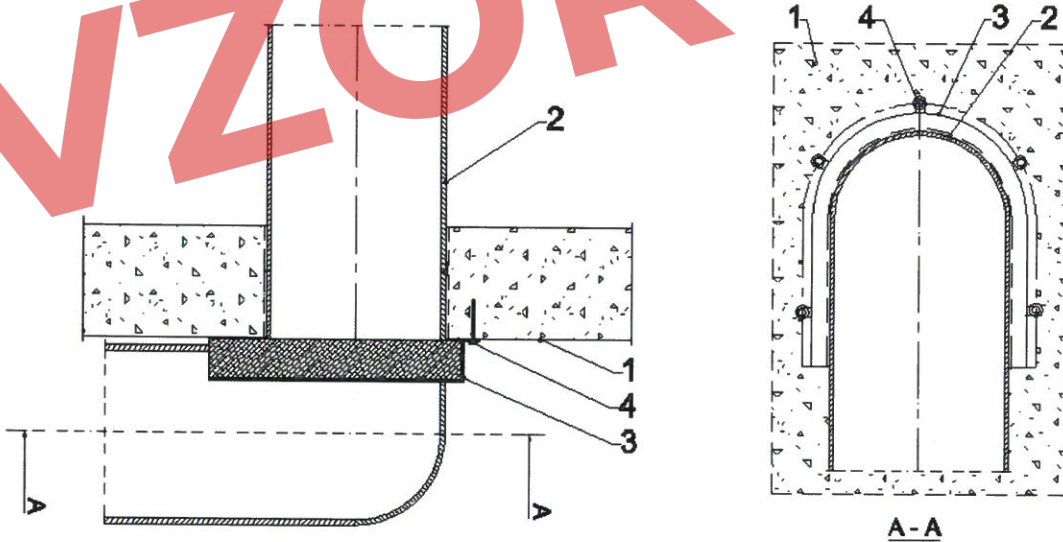

- 1 Rigid floor with thickness ≥ 150 mm and density ≥ 600 kg/m³
- 2 Plastic pipe
- 3 PS collar, fixed at the bottom of the floor
- 4 Fastener M6x60, number of fasteners in accordance with Annex A

Resistance to fire classification of plastic pipe elbow penetration seals in rigid floor, made with use of PS Collar:

Table C17.1 PVC-U / PVC-C pipes

Pipe material	Pipe diameter, [mm]	Pipe wall thickness, [mm]	Intumescent material		Fire resistance class
			width, [mm]	thickness, [mm]	
PVC-U / PVC-C	$\varnothing \leq 63$	2,0 – 5,1	30	5,0	EI 90 – U/C EI 90 – C/C
	$63 < \varnothing \leq 86$	2,3 – 5,7	30	7,5	
	$86 < \varnothing \leq 110$	2,6 – 6,5	30	10,0	
	$110 < \varnothing \leq 135$	2,9 – 5,6	30	12,5	
	$135 < \varnothing \leq 160$	3,2 – 4,7	30	15,0	

PS Collar and PS-25 Wrap

Annex C17

Construction details and resistance to fire classification of penetration seals made with use of PS Collar
Plastic pipe elbow penetration seal in rigid floor

of European
Technical Assessment
ETA-17/0676

Plastic pipe penetration seal in rigid floor, made with use of PS Collar, placed in angle between 0° and 89° to the floor.

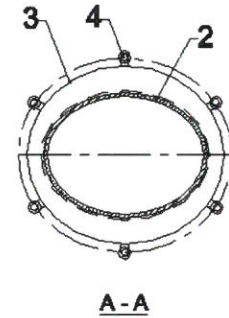
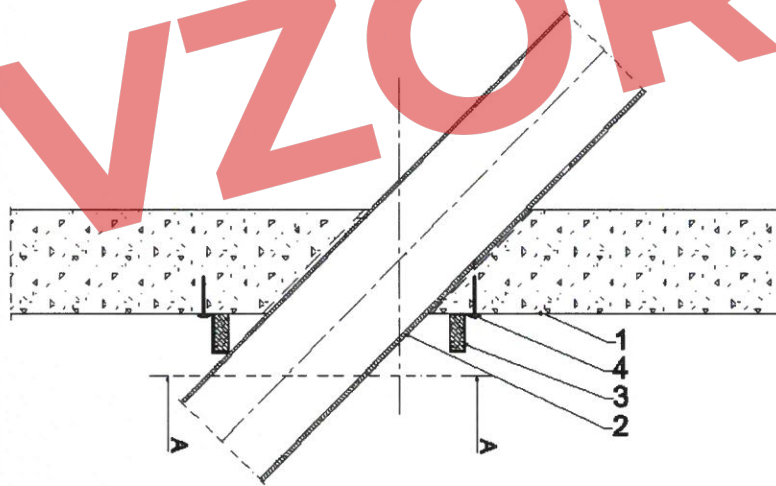

- 1 Rigid floor with thickness ≥ 150 mm and density ≥ 600 kg/m³
- 2 Plastic pipe
- 3 PS collar, fixed at the bottom of the floor
- 4 Fastener M6x60, number of fasteners in accordance with Annex A

Resistance to fire classification of plastic pipes penetration seals in rigid floor, made with use of PS Collar, placed in angle between 0° and 89° to the floor:

Table C18.1 PVC-U / PVC-C pipes

Pipe material	Pipe diameter, [mm]	Pipe wall thickness, [mm]	Intumescent material		Fire resistance class
			width, [mm]	thickness, [mm]	
PVC-U / PVC-C	$\varnothing \leq 32$	1,8 – 3,4	30	5,0	EI 120 – U/C EI 120 – C/C
	$32 < \varnothing \leq 51$	2,2 – 4,1	30	7,5	
	$51 < \varnothing \leq 71$	2,5 – 4,9	30	10,0	
	$71 < \varnothing \leq 90$	2,9 – 5,7	30	12,5	
	$90 < \varnothing \leq 110$	3,2 – 6,5	30	15,0	
	$110 < \varnothing \leq 135$	3,2 – 5,6	60	17,5	
	$135 < \varnothing \leq 160$	3,2 – 4,7	60	20,0	

PS Collar and PS-25 Wrap

Annex C18

Construction details and resistance to fire classification of penetration seals made with use of PS Collar
Plastic pipe penetration seal in rigid floor

of European
Technical Assessment
ETA-17/0676

Plastic pipes bundle penetration seal in rigid floor, made with use of PS Collar.

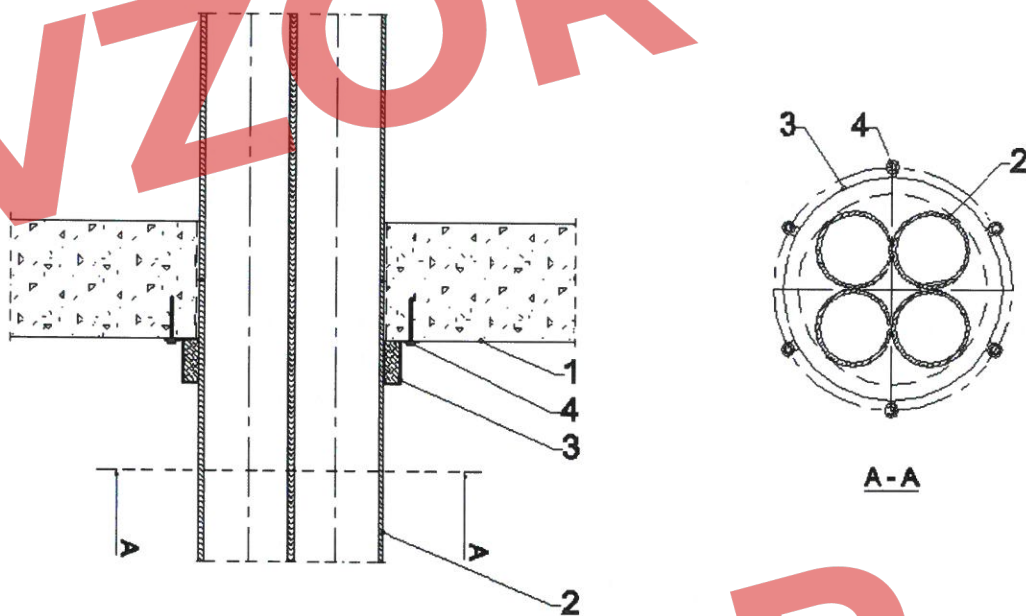

- 1 Rigid floor with thickness ≥ 150 mm and density ≥ 600 kg/m³
- 2 Plastic pipe (maximum 4 pipes in bundle)
- 3 PS collar, fixed at the bottom of the floor
- 4 Fastener M6x60, number of fasteners in accordance with Annex A

Resistance to fire classification of plastic pipes bundle penetration seals in rigid floor, made with use of PS Collar:

Table C19.1 PP-R pipes (maximum 4 pipes in bundle)

Pipe material	Single pipe diameter, [mm]	Pipe wall thickness, [mm]	Intumescent material		Fire resistance class
			width, [mm]	thickness, [mm]	
PP-R	$\varnothing \leq 32$	2,9 – 5,4	30	7,5	EI 120 – U/C EI 120 – C/C
	$32 < \varnothing \leq 40$	3,5 – 6,7	60	10,0	
	$40 < \varnothing \leq 49$	4,1 – 8,2	60	12,5	
	$49 < \varnothing \leq 57$	4,6 – 9,5	60	15,0	
	$57 < \varnothing \leq 66$	5,2 – 11,0	60	17,5	
	$66 < \varnothing \leq 75$	5,8 – 12,5	60	20,0	

PS Collar and PS-25 Wrap

Annex C19

Construction details and resistance to fire classification of penetration seals made with use of PS Collar
Plastic pipes bundle penetration seal in rigid floor

of European
Technical Assessment
ETA-17/0676

Plastic pipe penetration seal in rigid floor, made with use of PS Collar.

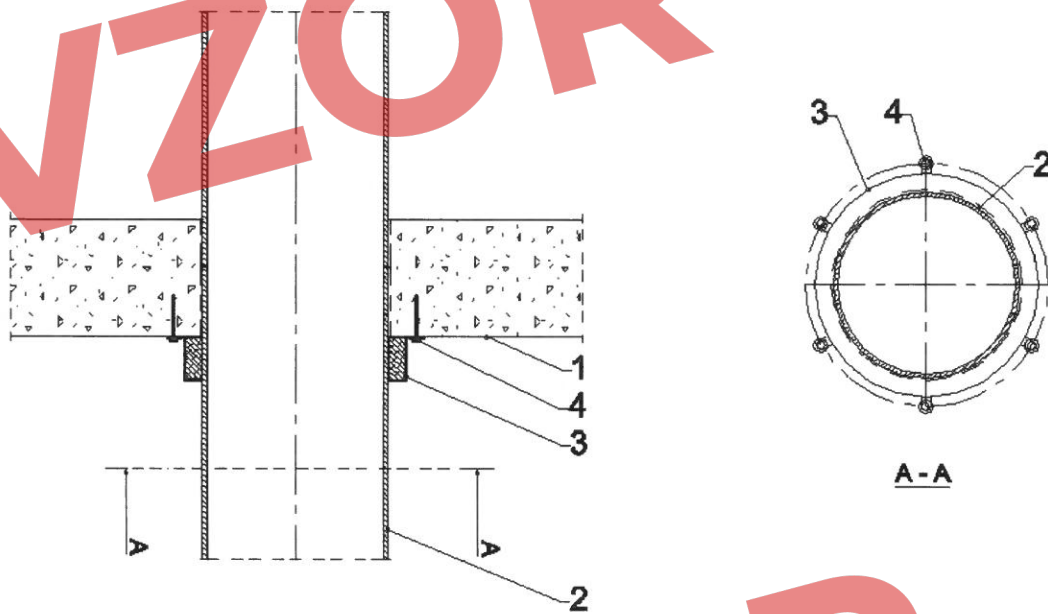

- 1 Rigid floor with thickness ≥ 150 mm and density ≥ 600 kg/m³
- 2 Plastic pipe
- 3 PS collar, fixed at the bottom of the floor
- 4 Fastener M6x60, number of fasteners in accordance with Annex A

PS Collar and PS-25 Wrap

**Construction details of penetration seals
made with use of PS Collar**
Plastic pipe penetration seal in rigid floor

Annex C20

of European
Technical Assessment
ETA-17/0676

Resistance to fire classification of plastic pipes penetration seals in rigid floor, made with use of PS Collar, in accordance with Annex C20:

Table C21.1 PE-HD pipes

Pipe material	Pipe diameter, [mm]	Pipe wall thickness, [mm]	Intumescent material		Fire resistance class
			width, [mm]	thickness, [mm]	
PE-HD	$\varnothing \leq 63$	3,0 – 5,8	30	5,0	EI 120 – U/C EI 120 – C/C
	$63 < \varnothing \leq 87$	3,8 – 7,9	30	7,5	
	$87 < \varnothing \leq 111$	4,6 – 10,1	30	10,0	
	$111 < \varnothing \leq 135$	5,4 – 12,3	30	12,5	
	$135 < \varnothing \leq 160$	6,2 – 14,6	30	15,0	
	$160 < \varnothing \leq 205$	7,9 – 12,1	60	17,5	
	$205 < \varnothing \leq 250$	9,6	60	20,0	

Table C21.2 PP-R pipes

Pipe material	Pipe diameter, [mm]	Pipe wall thickness, [mm]	Intumescent material		Fire resistance class
			width, [mm]	thickness, [mm]	
PP-R	$\varnothing \leq 63$	5,8 – 10,5	30	5,0	EI 120 – U/C EI 120 – C/C
	$63 < \varnothing \leq 87$	5,8 – 9,2	30	7,5	
	$87 < \varnothing \leq 111$	5,8 – 8,0	30	10,0	
	$111 < \varnothing \leq 135$	5,7 – 6,8	30	12,5	
	$135 < \varnothing \leq 160$	5,6	30	15,0	

Table C21.3 PVC-U / PVC-C pipes

Pipe material	Pipe diameter, [mm]	Pipe wall thickness, [mm]	Intumescent material		Fire resistance class
			width, [mm]	thickness, [mm]	
PVC-U / PVC-C	$\varnothing \leq 63$	2,0 – 5,1	30	5,0	EI 120 – U/C EI 120 – C/C
	$63 < \varnothing \leq 87$	2,3 – 5,0	30	7,5	
	$87 < \varnothing \leq 111$	2,6 – 4,9	30	10,0	
	$111 < \varnothing \leq 135$	2,9 – 4,8	30	12,5	
	$135 < \varnothing \leq 160$	3,2 – 4,7	30	15,0	
	$160 < \varnothing \leq 205$	4,7 – 8,5	60	17,5	
	$205 < \varnothing \leq 250$	6,2 – 9,6	60	20,0	

PS Collar and PS-25 Wrap

Resistance to fire classification of penetration seals made with use of PS Collar
Plastic pipe penetration seal in rigid floor

Annex C21

of European
Technical Assessment
ETA-17/0676

Plastic pipe penetration seal in rigid floor, made with use of PS Collar – pipe elbow on the bottom of the floor.

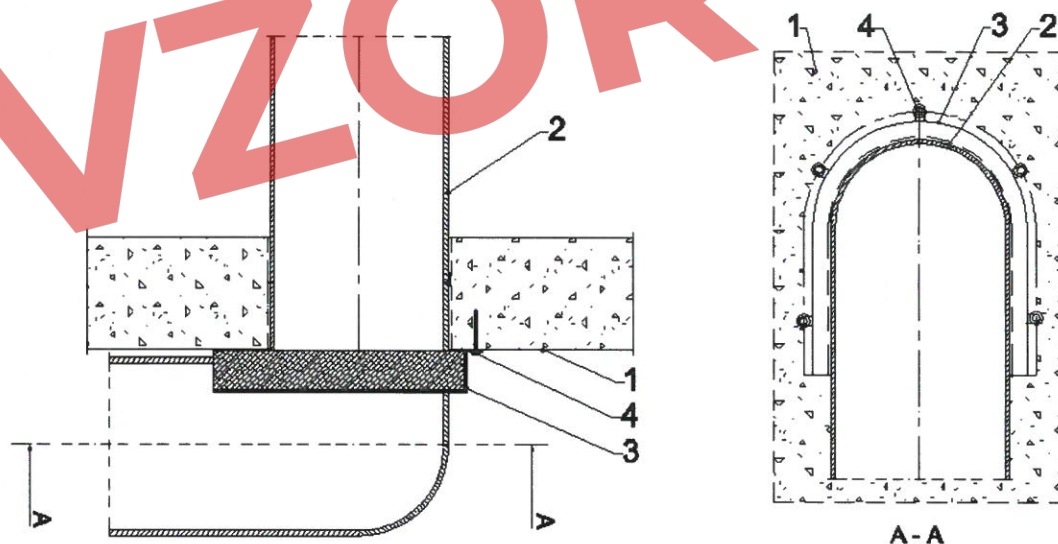

- 1 Rigid floor with thickness ≥ 150 mm and density ≥ 600 kg/m³
- 2 Plastic pipe
- 3 PS collar, fixed at the bottom of the floor
- 4 Fastener M6x60, number of fasteners in accordance with Annex A

Resistance to fire classification of plastic pipe elbow penetration seals in rigid floor, made with use of PS Collar:

Table C22.1 PVC-U / PVC-C pipes

Pipe material	Pipe diameter, [mm]	Pipe wall thickness, [mm]	Intumescent material		Fire resistance class
			width, [mm]	thickness, [mm]	
PVC-U / PVC-C	$\varnothing \leq 63$	2,0 – 5,1	30	5,0	EI 120 – U/C EI 120 – C/C
	$63 < \varnothing \leq 86$	2,3 – 5,7	30	7,5	
	$86 < \varnothing \leq 110$	2,6 – 6,5	30	10,0	
	$110 < \varnothing \leq 135$	2,9 – 5,6	30	12,5	
	$135 < \varnothing \leq 160$	3,2 – 4,7	30	15,0	

PS Collar and PS-25 Wrap

Annex C22

Construction details and resistance to fire classification of penetration seals made with use of PS Collar
Plastic pipe elbow penetration seal in rigid floor

of European
Technical Assessment
ETA-17/0676

Plastic pipe penetration seal in rigid wall, made with use of PS-25 Wrap.

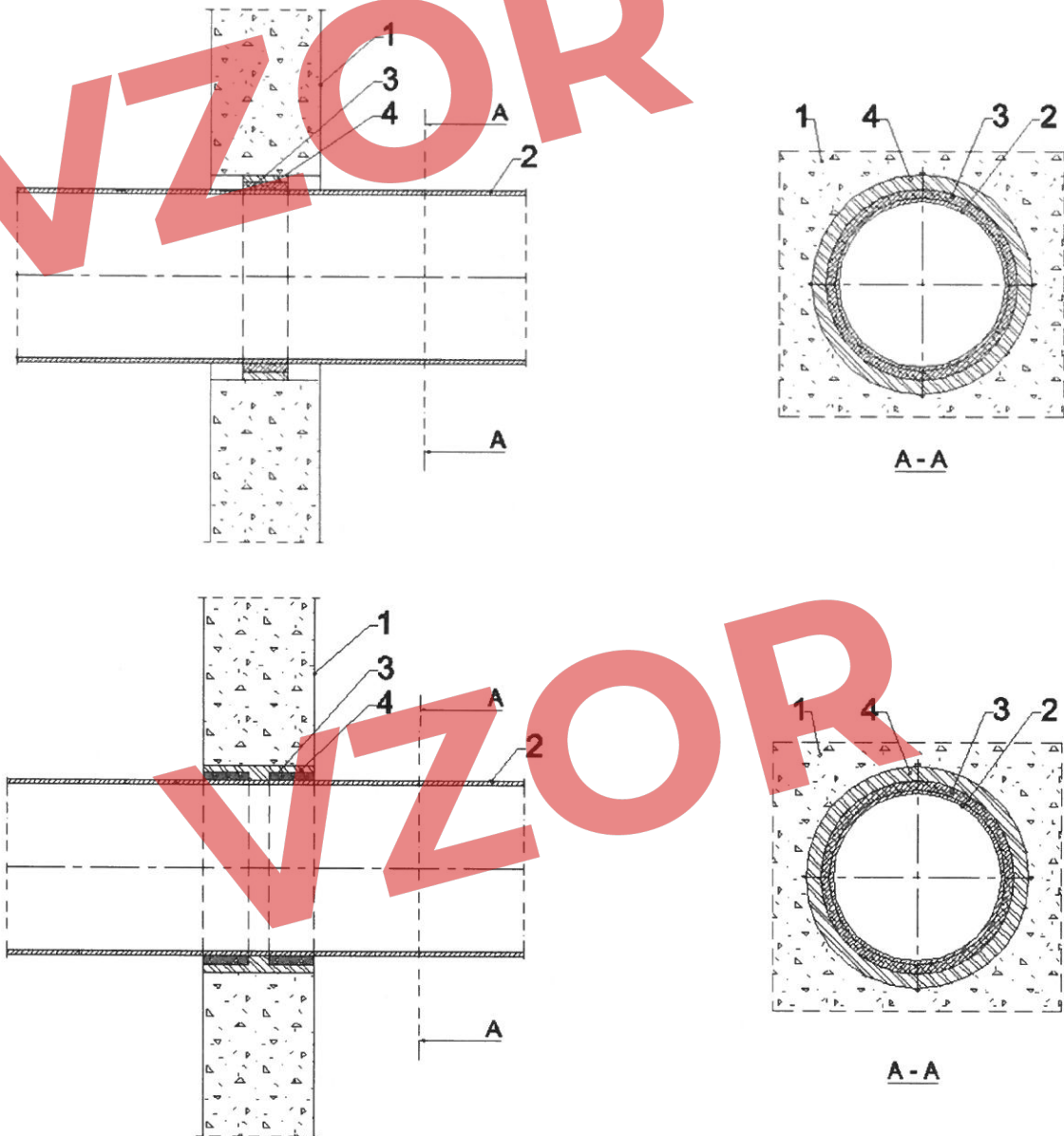

- 1 Rigid wall with thickness $\geq 100 \text{ mm}^*)$ and density $\geq 600 \text{ kg/m}^3$
 - 2 Plastic pipe
 - 3 PS-25 Wrap:
 - one wrap for pipes with diameter $\leq 75 \text{ mm}$, placed in the centre of the wall thickness
 - two wraps for pipes with diameter $> 75 \text{ mm}$, placed symmetrically on both sides of the axis of the wall
 - 4 Gap filler (cement or gypsum mortar); gap width $\leq 15 \text{ mm}$
- ^{*)} In certain cases wall thickness is increased to $\geq 150 \text{ mm}$, by means of two layers of 12,5 mm thick 'Type F' gypsum plasterboards according to EN 520, placed on both sides of the wall (see Table C24.3 in Annex C24)

PS Collar and PS-25 Wrap

Annex C23

**Construction details of penetration seals
made with use of PS-25 Wrap**
Plastic pipe penetration seal in rigid wall

of European
Technical Assessment
ETA-17/0676

Resistance to fire classification of plastic pipes penetration seals in rigid wall, made with use of PS-25 Wrap, in accordance with Annex C23:

Table C24.1 PE-HD pipes

Pipe material	Pipe diameter, [mm]	Pipe wall thickness, [mm]	Intumescent material		Fire resistance class
			width, [mm]	thickness, [mm]	
PE-HD	$\varnothing \leq 75$	3,0 – 6,8	60	5,0	EI 60 – U/C EI 60 – C/C
	$75 < \varnothing \leq 96$	3,8 – 8,7	60	7,5	
	$96 < \varnothing \leq 117$	4,6 – 10,6	60	10,0	
	$117 < \varnothing \leq 138$	5,4 – 12,5	60	12,5	
	$138 < \varnothing \leq 160$	6,2 – 14,6	60	15,0	
	$160 < \varnothing \leq 205$	7,9 – 14,6	60	17,5	
	$205 < \varnothing \leq 250$	9,6 – 14,6	60	20,0	

Table C24.2 PP-R pipes

Pipe material	Pipe diameter, [mm]	Pipe wall thickness, [mm]	Intumescent material		Fire resistance class
			width, [mm]	thickness, [mm]	
PP-R	$\varnothing \leq 75$	6,8 – 12,5	60	5,0	EI 60 – U/C EI 60 – C/C
	$75 < \varnothing \leq 96$	6,6 – 13,0	60	7,5	
	$96 < \varnothing \leq 117$	6,3 – 13,5	60	10,0	
	$117 < \varnothing \leq 138$	6,0 – 14,0	60	12,5	
	$138 < \varnothing \leq 160$	5,6 – 14,6	60	15,0	

Table C24.3 PVC-U / PVC-C pipes

Pipe material	Pipe diameter, [mm]	Pipe wall thickness, [mm]	Intumescent material		Fire resistance class
			width, [mm]	thickness, [mm]	
PVC-U / PVC-C	$\varnothing \leq 75$	1,8 – 6,5	60	5,0	EI 60 – U/C EI 60 – C/C
		2,2 – 6,0	60	7,5	EI 60 – U/C ^{*)} EI 60 – C/C ^{*)}
	$75 < \varnothing \leq 96$	2,8 – 6,8 ^{*)}	60 ^{*)}	7,5 ^{*)}	EI 60 – U/C ^{*)} EI 60 – C/C ^{*)}
		2,5 – 5,6	60	10,0	EI 60 – U/C EI 60 – C/C
	$96 < \varnothing \leq 117$	3,7 – 7,2 ^{*)}	60 ^{*)}	10,0 ^{*)}	EI 60 – U/C ^{*)} EI 60 – C/C ^{*)}
		2,9 – 5,1	60	12,5	EI 60 – U/C EI 60 – C/C
	$117 < \varnothing \leq 138$	4,7 – 7,6 ^{*)}	60 ^{*)}	12,5 ^{*)}	EI 60 – U/C ^{*)} EI 60 – C/C ^{*)}

PS Collar and PS-25 Wrap

Annex C24

Resistance to fire classification of penetration seals
made with use of PS-25 Wrap

Plastic pipe penetration seal in rigid wall

of European
Technical Assessment
ETA-17/0676

Table C24.3 (continued) PVC-U / PVC-C pipes

Pipe material	Pipe diameter, [mm]	Pipe wall thickness, [mm]	Intumescent material		Fire resistance class
			width, [mm]	thickness, [mm]	
PVC-U / PVC-C	138 < Ø ≤ 160	3,2 – 4,7	60	15,0	EI 60 – U/C EI 60 – C/C
		4,7 – 8,0 ^{*)}	60 ^{*)}	15,0 ^{*)}	EI 60 – U/C ^{*)} EI 60 – C/C ^{*)}
	160 < Ø ≤ 205	4,7 – 8,8 ^{*)}	60 ^{*)}	17,5 ^{*)}	
	205 < Ø ≤ 250	6,2 – 9,6 ^{*)}	60 ^{*)}	20,0 ^{*)}	

^{*)} wall thickness ≥ 150 mm (initial thickness increased by two layers of 12,5 mm thick 'Type F' gypsum plasterboards according to EN 520, placed on both sides of the wall)

VZOR

VZOR

PS Collar and PS-25 Wrap

Annex C24

Resistance to fire classification of penetration seals
made with use of PS-25 Wrap
Plastic pipe penetration seal in rigid wall

of European
Technical Assessment
ETA-17/0676

Plastic pipe penetration seal in rigid wall, made with use of PS-25 Wrap.

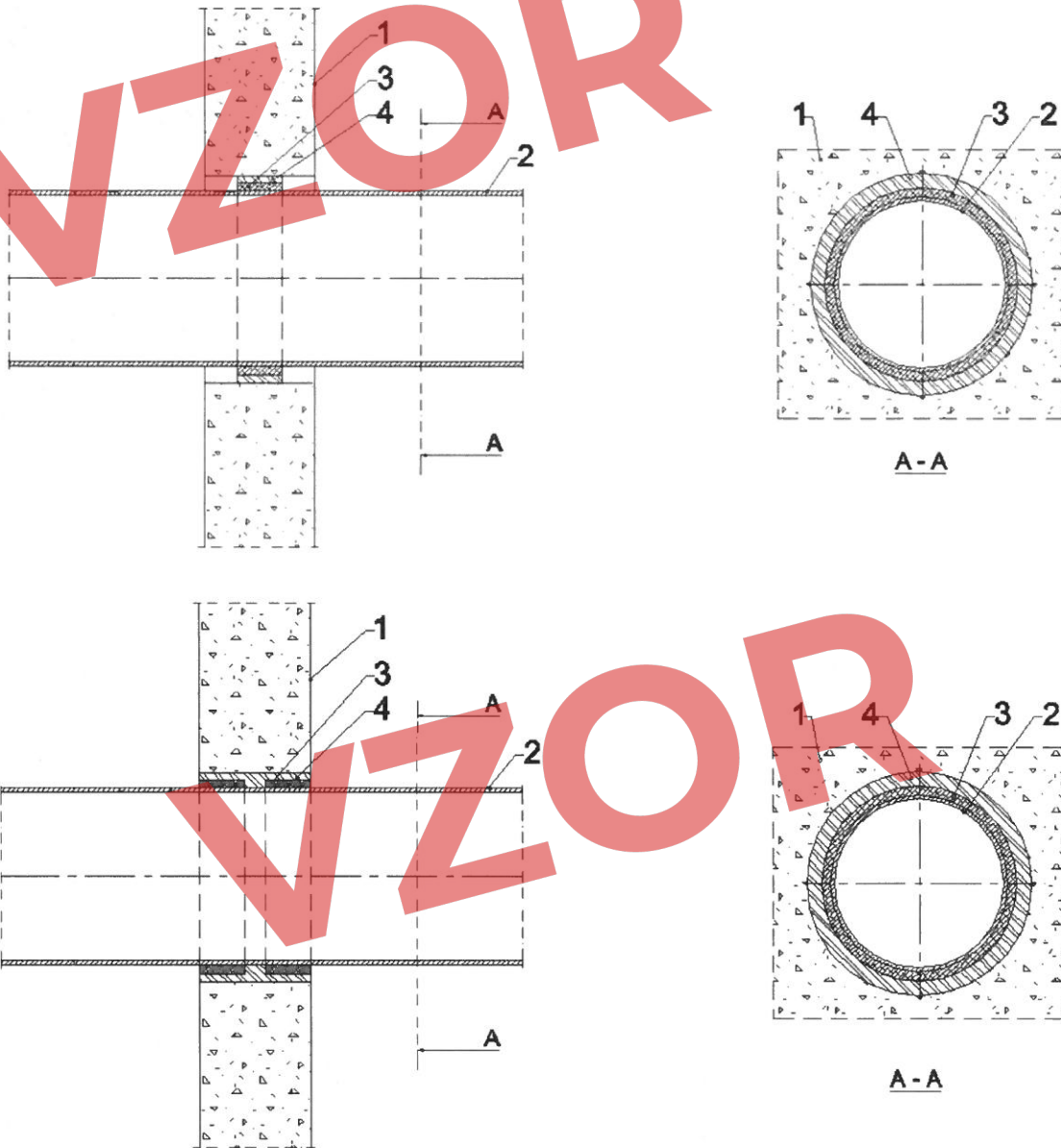

- 1 Rigid wall with thickness $\geq 100 \text{ mm}$ ^{*)} and density $\geq 600 \text{ kg/m}^3$
 - 2 Plastic pipe
 - 3 PS-25 Wrap:
 - one wrap for pipes with diameter $\leq 75 \text{ mm}$, placed in the centre of the wall thickness
 - two wraps for pipes with diameter $> 75 \text{ mm}$, placed symmetrically on both sides of the axis of the wall
 - 4 Gap filler (cement or gypsum mortar); gap width $\leq 15 \text{ mm}$
- ^{*)} In certain cases wall thickness is increased to $\geq 150 \text{ mm}$, by means of two layers of 12,5 mm thick 'Type F' gypsum plasterboards according to EN 520, placed on both sides of the wall (see Table C26.3 in Annex C26)

PS Collar and PS-25 Wrap

**Construction details of penetration seals
made with use of PS-25 Wrap**
Plastic pipe penetration seal in rigid wall

Annex C25

of European
Technical Assessment
ETA-17/0676

Resistance to fire classification of plastic pipes penetration seals in rigid wall, made with use of PS-25 Wrap, in accordance with Annex C25:

Table C26.1 PE-HD pipes

Pipe material	Pipe diameter, [mm]	Pipe wall thickness, [mm]	Intumescent material		Fire resistance class
			width, [mm]	thickness, [mm]	
PE-HD	$\varnothing \leq 75$	3,0 – 6,8	60	5,0	EI 90 – U/C EI 90 – C/C
	$75 < \varnothing \leq 96$	4,4 – 8,7	60	7,5	
	$96 < \varnothing \leq 117$	5,8 – 10,6	60	10,0	
	$117 < \varnothing \leq 138$	7,2 – 12,5	60	12,5	
	$138 < \varnothing \leq 160$	8,7 – 14,6	60	15,0	
	$160 < \varnothing \leq 205$	11,7 – 14,6	60	17,5	
	$205 < \varnothing \leq 250$	14,6	60	20,0	

Table C26.2 PP-R pipes

Pipe material	Pipe diameter, [mm]	Pipe wall thickness, [mm]	Intumescent material		Fire resistance class
			width, [mm]	thickness, [mm]	
PP-R	$\varnothing \leq 75$	6,8 – 12,5	60	5,0	EI 90 – U/C EI 90 – C/C
	$75 < \varnothing \leq 96$	6,6 – 13,0	60	7,5	
	$96 < \varnothing \leq 117$	6,3 – 13,5	60	10,0	
	$117 < \varnothing \leq 138$	6,0 – 14,0	60	12,5	
	$138 < \varnothing \leq 160$	5,6 – 14,6	60	15,0	

Table C26.3 PVC-U / PVC-C pipes

Pipe material	Pipe diameter, [mm]	Pipe wall thickness, [mm]	Intumescent material		Fire resistance class
			width, [mm]	thickness, [mm]	
PVC-U / PVC-C	$\varnothing \leq 75$	1,8 – 6,5	60	5,0	EI 90 – U/C EI 90 – C/C
		2,2 – 6,0	60	7,5	
	$75 < \varnothing \leq 96$	2,8 – 6,8 ⁾	60 ⁾	7,5 ⁾	EI 90 – U/C ⁾ EI 90 – C/C ⁾
		2,5 – 5,6	60	10,0	
	$96 < \varnothing \leq 117$	3,7 – 7,2 ⁾	60 ⁾	10,0 ⁾	EI 90 – U/C ⁾ EI 90 – C/C ⁾
		2,9 – 5,1	60	12,5	
	$117 < \varnothing \leq 138$	4,7 – 7,6 ⁾	60 ⁾	12,5 ⁾	EI 90 – U/C ⁾ EI 90 – C/C ⁾

PS Collar and PS-25 Wrap

Annex C26

Resistance to fire classification of penetration seals
made with use of PS-25 Wrap
Plastic pipe penetration seal in rigid wall

of European
Technical Assessment
ETA-17/0676

Table C26.3 (continued) PVC-U / PVC-C pipes

Pipe material	Pipe diameter, [mm]	Pipe wall thickness, [mm]	Intumescent material		Fire resistance class
			width, [mm]	thickness, [mm]	
PVC-U / PVC-C	138 < Ø ≤ 160	3,2 – 4,7	60	15,0	EI 90 – U/C EI 90 – C/C
		4,7 – 8,0 ⁾	60 ⁾	15,0 ⁾	EI 90 – U/C ⁾ EI 90 – C/C ⁾
	160 < Ø ≤ 205	4,7 – 8,8 ⁾	60 ⁾	17,5 ⁾	
	205 < Ø ≤ 250	6,2 – 9,6 ⁾	60 ⁾	20,0 ⁾	

⁾ wall thickness ≥ 150 mm (initial thickness increased by two layers of 12,5 mm thick 'Type F' gypsum plasterboards according to EN 520, placed on both sides of the wall)

VZOR

VZOR

PS Collar and PS-25 Wrap

Annex C26

Resistance to fire classification of penetration seals
made with use of PS-25 Wrap

Plastic pipe penetration seal in rigid wall

of European
Technical Assessment
ETA-17/0676

Plastic pipe penetration seal in rigid wall, made with use of PS-25 Wrap.

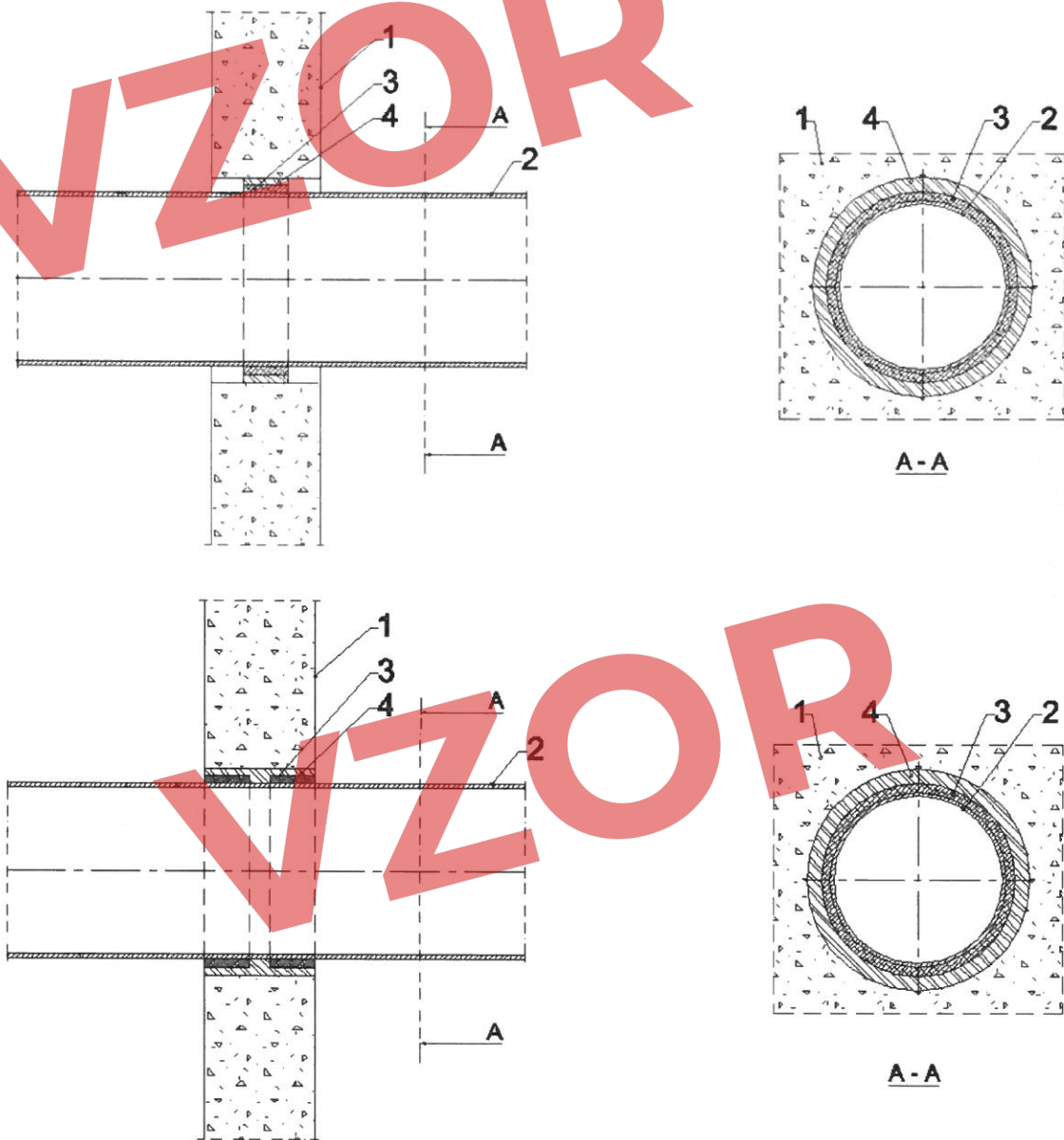

- 1 Rigid wall with thickness $\geq 100 \text{ mm}$ ¹⁾ and density $\geq 600 \text{ kg/m}^3$
 - 2 Plastic pipe
 - 3 PS-25 Wrap:
 - one wrap for pipes with diameter $\leq 75 \text{ mm}$, placed in the centre of the wall thickness
 - two wraps for pipes with diameter $> 75 \text{ mm}$, placed symmetrically on both sides of the axis of the wall
 - 4 Gap filler (cement or gypsum mortar); gap width $\leq 15 \text{ mm}$
- ¹⁾ In certain cases wall thickness is increased to $\geq 150 \text{ mm}$, by means of two layers of 12,5 mm thick 'Type F' gypsum plasterboards according to EN 520, placed on both sides of the wall (see Table C28.3 in Annex C28)

PS Collar and PS-25 Wrap

**Construction details of penetration seals
made with use of PS-25 Wrap**
Plastic pipe penetration seal in rigid wall

Annex C27

of European
Technical Assessment
ETA-17/0676

Resistance to fire classification of plastic pipes penetration seals in rigid wall, made with use of PS-25 Wrap, in accordance with Annex C27:

Table C28.1 PE-HD pipes

Pipe material	Pipe diameter, [mm]	Pipe wall thickness, [mm]	Intumescent material		Fire resistance class
			width, [mm]	thickness, [mm]	
PE-HD	$\varnothing \leq 75$	3,0 – 6,8	60	5,0	EI 120 – U/C EI 120 – C/C
	$75 < \varnothing \leq 96$	4,4 – 8,7	60	7,5	
	$96 < \varnothing \leq 117$	5,8 – 10,6	60	10,0	
	$117 < \varnothing \leq 138$	7,2 – 12,5	60	12,5	
	$138 < \varnothing \leq 160$	8,7 – 14,6	60	15,0	
	$160 < \varnothing \leq 205$	11,7 – 14,6	60	17,5	
	$205 < \varnothing \leq 250$	14,6	60	20,0	

Table C28.2 PP-R pipes

Pipe material	Pipe diameter, [mm]	Pipe wall thickness, [mm]	Intumescent material		Fire resistance class
			width, [mm]	thickness, [mm]	
PP-R	$\varnothing \leq 75$	6,8 – 12,5	60	5,0	EI 120 – U/C EI 120 – C/C
	$75 < \varnothing \leq 96$	8,8 – 13,0	60	7,5	
	$96 < \varnothing \leq 117$	10,7 – 13,5	60	10,0	
	$117 < \varnothing \leq 138$	12,6 – 14,0	60	12,5	
	$138 < \varnothing \leq 160$	8,7 – 14,6	60	15,0	

Table C28.3 PVC-U / PVC-C pipes

Pipe material	Pipe diameter, [mm]	Pipe wall thickness, [mm]	Intumescent material		Fire resistance class
			width, [mm]	thickness, [mm]	
PVC-U / PVC-C	$\varnothing \leq 75$	1,8 – 6,5	60	5,0	EI 120 – U/C EI 120 – C/C
	$75 < \varnothing \leq 96$	2,8 – 6,8 ^{*)}	60 ^{*)}	7,5 ^{*)}	
	$96 < \varnothing \leq 117$	3,7 – 7,2 ^{*)}	60 ^{*)}	10,0 ^{*)}	EI 120 – U/C ^{*)} EI 120 – C/C ^{*)}
	$117 < \varnothing \leq 138$	4,7 – 7,6 ^{*)}	60 ^{*)}	12,5 ^{*)}	
	$138 < \varnothing \leq 160$	5,6 – 8,0 ^{*)}	60 ^{*)}	15,0 ^{*)}	
	$160 < \varnothing \leq 205$	7,6 – 8,8 ^{*)}	60 ^{*)}	17,5 ^{*)}	
	$205 < \varnothing \leq 250$	9,6 ^{*)}	60 ^{*)}	20,0 ^{*)}	

^{*)} wall thickness ≥ 150 mm (initial thickness increased by two layers of 12,5 mm thick 'Type F' gypsum plasterboards according to EN 520, placed on both sides of the wall)

PS Collar and PS-25 Wrap

Resistance to fire classification of penetration seals made with use of PS-25 Wrap
Plastic pipe penetration seal in rigid wall

Annex C28

of European
Technical Assessment
ETA-17/0676

Plastic pipe penetration seal in rigid floor, made with use of PS-25 Wrap.

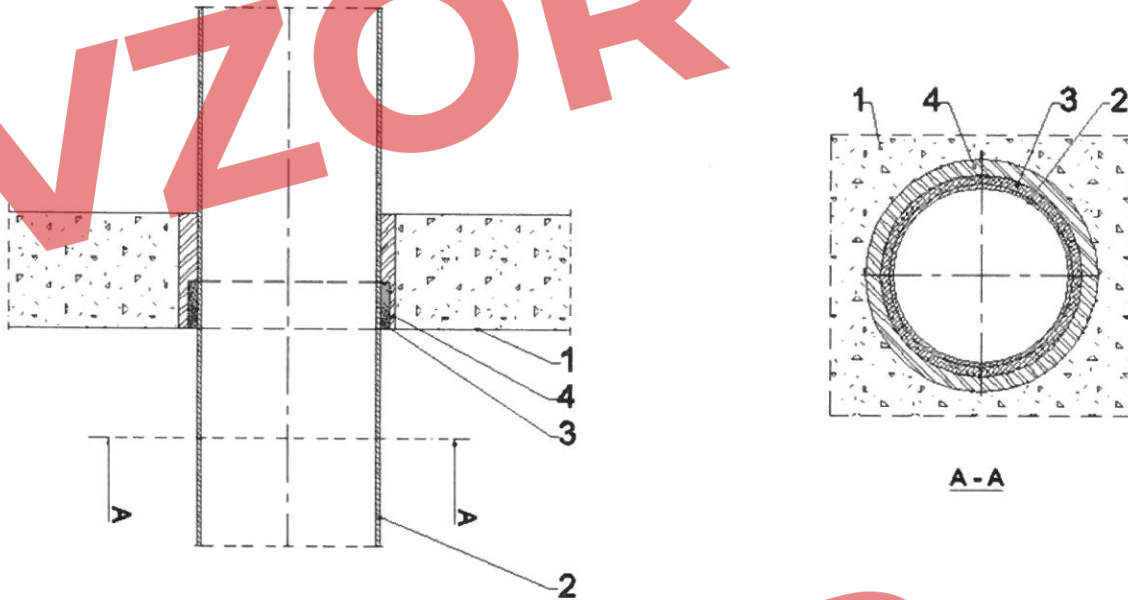

- 1 Rigid floor with thickness ≥ 150 mm and density ≥ 600 kg/m³
- 2 Plastic pipe
- 3 PS-25 Wrap placed on the bottom of the floor
- 4 Gap filler (cement or gypsum mortar), gap width ≤ 15 mm

PS Collar and PS-25 Wrap

**Construction details of penetration seals
made with use of PS-25 Wrap**
Plastic pipe penetration seal in rigid floor

Annex C29

of European
Technical Assessment
ETA-17/0676

Resistance to fire classification of plastic pipes penetration seals in rigid floor, made with use of PS-25 Wrap, in accordance with Annex C29:

Table C30.1 PE-HD pipes

Pipe material	Pipe diameter, [mm]	Pipe wall thickness, [mm]	Intumescent material		Fire resistance class
			width, [mm]	thickness, [mm]	
PE-HD	$\varnothing \leq 75$	3,0 – 6,8	60	5,0	EI 45 – U/C EI 45 – C/C
	$75 < \varnothing \leq 96$	3,8 – 8,7	60	7,5	
	$96 < \varnothing \leq 117$	4,6 – 10,6	60	10,0	
	$117 < \varnothing \leq 138$	5,4 – 12,5	60	12,5	
	$138 < \varnothing \leq 160$	6,2 – 14,6	60	15,0	
	$160 < \varnothing \leq 205$	7,9 – 14,6	60	17,5	
	$205 < \varnothing \leq 250$	9,6 – 14,6	60	20,0	

Table C30.2 PP-R pipes

Pipe material	Pipe diameter, [mm]	Pipe wall thickness, [mm]	Intumescent material		Fire resistance class
			width, [mm]	thickness, [mm]	
PP-R	$\varnothing \leq 75$	6,8 – 12,5	60	5,0	EI 45 – U/C EI 45 – C/C
	$75 < \varnothing \leq 96$	6,6 – 13,0	60	7,5	
	$96 < \varnothing \leq 117$	6,3 – 13,5	60	10,0	
	$117 < \varnothing \leq 138$	6,0 – 14,0	60	12,5	
	$138 < \varnothing \leq 160$	5,6 – 14,6	60	15,0	

Table C30.3 PVC-U / PVC-C pipes

Pipe material	Pipe diameter, [mm]	Pipe wall thickness, [mm]	Intumescent material		Fire resistance class
			width, [mm]	thickness, [mm]	
PVC-U / PVC-C	$\varnothing \leq 75$	1,8 – 6,5	60	5,0	EI 45 – U/C EI 45 – C/C
	$75 < \varnothing \leq 96$	2,2 – 6,8	60	7,5	
	$96 < \varnothing \leq 117$	2,5 – 7,2	60	10,0	
	$117 < \varnothing \leq 138$	2,9 – 7,6	60	12,5	
	$138 < \varnothing \leq 160$	3,2 – 8,0	60	15,0	
	$160 < \varnothing \leq 205$	4,7 – 8,8	60	17,5	
	$205 < \varnothing \leq 250$	6,2 – 9,5	60	20,0	
		9,7 – 14,6	60	20,0	

PS Collar and PS-25 Wrap

Resistance to fire classification of penetration seals
made with use of PS-25 Wrap
Plastic pipe penetration seal in rigid floor

Annex C30

of European
Technical Assessment
ETA-17/0676

Plastic pipe penetration seal in rigid floor, made with use of PS-25 Wrap.

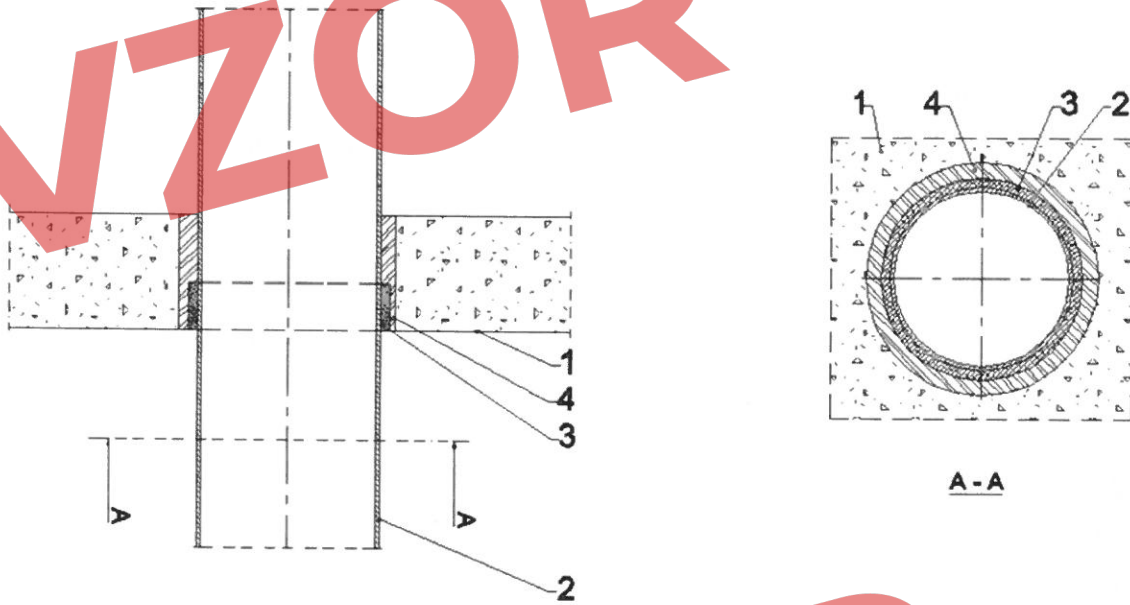

- 1 Rigid floor with thickness ≥ 150 mm and density ≥ 600 kg/m³
- 2 Plastic pipe
- 3 PS-25 Wrap placed on the bottom of the floor
- 4 Gap filler (cement or gypsum mortar); gap width ≤ 15 mm

PS Collar and PS-25 Wrap

**Construction details of penetration seals
made with use of PS-25 Wrap**
Plastic pipe penetration seal in rigid floor

Annex C31

of European
Technical Assessment
ETA-17/0676

Resistance to fire classification of plastic pipes penetration seals in rigid floor, made with use of PS-25 Wrap, in accordance with Annex C31:

Table C32.1 PE-HD pipes

Pipe material	Pipe diameter, [mm]	Pipe wall thickness, [mm]	Intumescent material		Fire resistance class
			width, [mm]	thickness, [mm]	
PE-HD	$\varnothing \leq 75$	3,0 – 6,8	60	5,0	EI 90 – U/C EI 90 – C/C
	$75 < \varnothing \leq 96$	3,8 – 8,7	60	7,5	
	$96 < \varnothing \leq 117$	4,6 – 10,6	60	10,0	
	$117 < \varnothing \leq 138$	5,4 – 12,5	60	12,5	
	$138 < \varnothing \leq 160$	6,2 – 14,6	60	15,0	
	$160 < \varnothing \leq 205$	7,9 – 14,6	60	17,5	
	$205 < \varnothing \leq 250$	9,6 – 14,6	60	20,0	

Table C32.2 PP-R pipes

Pipe material	Pipe diameter, [mm]	Pipe wall thickness, [mm]	Intumescent material		Fire resistance class
			width, [mm]	thickness, [mm]	
PP-R	$\varnothing \leq 75$	6,8 – 12,5	60	5,0	EI 90 – U/C EI 90 – C/C
	$75 < \varnothing \leq 96$	6,6 – 13,0	60	7,5	
	$96 < \varnothing \leq 117$	6,3 – 13,5	60	10,0	
	$117 < \varnothing \leq 138$	6,0 – 14,0	60	12,5	
	$138 < \varnothing \leq 160$	5,6 – 14,6	60	15,0	

Table C32.3 PVC-U / PVC-C pipes

Pipe material	Pipe diameter, [mm]	Pipe wall thickness, [mm]	Intumescent material		Fire resistance class
			width, [mm]	thickness, [mm]	
PVC-U / PVC-C	$\varnothing \leq 75$	1,8 – 6,5	60	5,0	EI 90 – U/C EI 90 – C/C
	$75 < \varnothing \leq 96$	2,2 – 6,8	60	7,5	
	$96 < \varnothing \leq 117$	2,5 – 7,2	60	10,0	
	$117 < \varnothing \leq 138$	2,9 – 7,6	60	12,5	
	$138 < \varnothing \leq 160$	3,2 – 8,0	60	15,0	
	$160 < \varnothing \leq 205$	6,4 – 8,8	60	17,5	
	$205 < \varnothing \leq 250$	9,7 – 14,6	60	20,0	

PS Collar and PS-25 Wrap

Annex C32

Resistance to fire classification of penetration seals made with use of PS-25 Wrap

Plastic pipe penetration seal in rigid floor

of European
Technical Assessment
ETA-17/0676

Plastic pipe penetration seal in rigid floor, made with use of PS-25 Wrap.

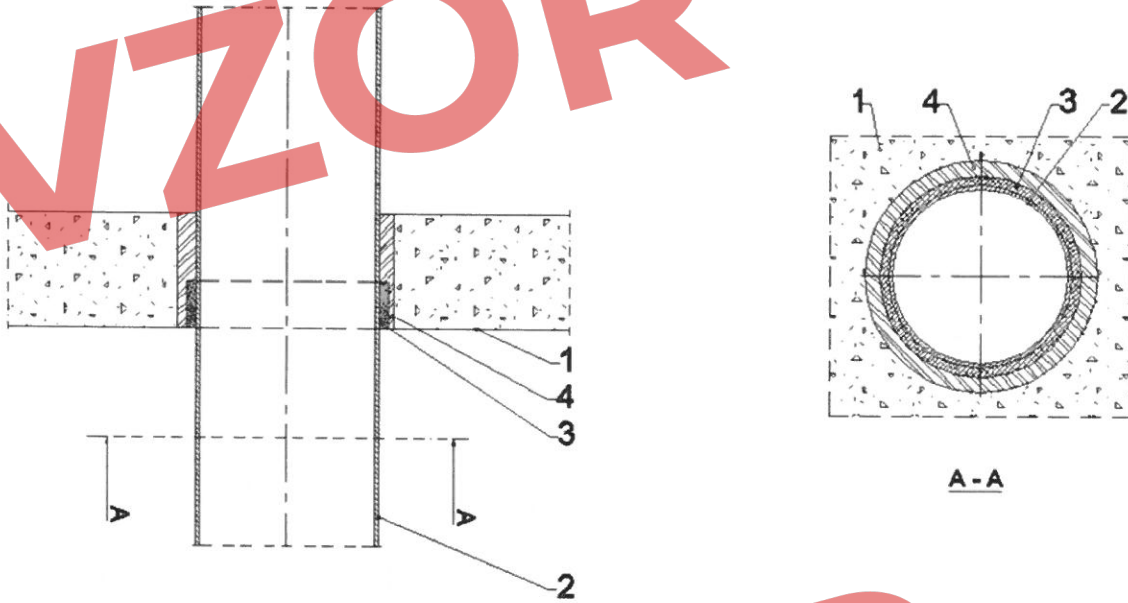

- 1 Rigid floor with thickness ≥ 150 mm and density ≥ 600 kg/m³
- 2 Plastic pipe
- 3 PS-25 Wrap placed on the bottom of the floor
- 4 Gap filler (cement or gypsum mortar); gap width ≤ 15 mm

PS Collar and PS-25 Wrap

**Construction details of penetration seals
made with use of PS-25 Wrap**
Plastic pipe penetration seal in rigid floor

Annex C33

of European
Technical Assessment
ETA-17/0676

Resistance to fire classification of plastic pipes penetration seals in rigid floor, made with use of PS-25 Wrap, in accordance with Annex C33:

Table C34.1 PE-HD pipes

Pipe material	Pipe diameter, [mm]	Pipe wall thickness, [mm]	Intumescent material		Fire resistance class
			width, [mm]	thickness, [mm]	
PE-HD	$\varnothing \leq 75$	3,0 – 6,8	60	5,0	EI 120 – U/C EI 120 – C/C
	$75 < \varnothing \leq 96$	3,8 – 8,7	60	7,5	
	$96 < \varnothing \leq 117$	4,6 – 10,6	60	10,0	
	$117 < \varnothing \leq 138$	5,4 – 12,5	60	12,5	
	$138 < \varnothing \leq 160$	6,2 – 14,6	60	15,0	
	$160 < \varnothing \leq 205$	7,9 – 12,1	60	17,5	
	$205 < \varnothing \leq 250$	9,6	60	20,0	

Table C34.2 PP-R pipes

Pipe material	Pipe diameter, [mm]	Pipe wall thickness, [mm]	Intumescent material		Fire resistance class
			width, [mm]	thickness, [mm]	
PP-R	$\varnothing \leq 75$	6,8 – 12,5	60	5,0	EI 120 – U/C EI 120 – C/C
	$75 < \varnothing \leq 96$	6,6 – 13,0	60	7,5	
	$96 < \varnothing \leq 117$	6,3 – 13,5	60	10,0	
	$117 < \varnothing \leq 138$	6,0 – 14,0	60	12,5	
	$138 < \varnothing \leq 160$	5,6 – 14,6	60	15,0	

Table C34.3 PVC-U / PVC-C pipes

Pipe material	Pipe diameter, [mm]	Pipe wall thickness, [mm]	Intumescent material		Fire resistance class
			width, [mm]	thickness, [mm]	
PVC-U / PVC-C	$\varnothing \leq 75$	1,8 – 6,5	60	5,0	EI 120 – U/C EI 120 – C/C
	$75 < \varnothing \leq 96$	2,2 – 6,8	60	7,5	
	$96 < \varnothing \leq 117$	2,5 – 7,2	60	10,0	
	$117 < \varnothing \leq 138$	2,9 – 7,6	60	12,5	
	$138 < \varnothing \leq 160$	3,2 – 8,0	60	15,0	
	$160 < \varnothing \leq 205$	6,4 – 8,8	60	17,5	
	$205 < \varnothing \leq 250$	9,7 – 14,6	60	20,0	

PS Collar and PS-25 Wrap

Resistance to fire classification of penetration seals
made with use of PS-25 Wrap
Plastic pipe penetration seal in rigid floor

Annex C34

of European
Technical Assessment
ETA-17/0676